

Conditioner Characteristics

Type	
Range	to °C

Sensor Readings	#1	#2	#3	#4
mV at °C				
mV at °C				

CAN parameters

Baudrate		bps
Frequency		Hz
Rx trig ID	0x	Hex
Tx1 ID	0x	Hex
Degree	0	° Fahrenheit
	1	° Celsius
CAN termination resistor	0	Not connected
	1	Connected

Cable

Type: 4x26AWG FEP tinned copper braided (250V 200°C)
 Length: mm Tubing:
 Connector:

Pinout

Colour	Function	Pin
Red	Supply	-
Black	Ground 0V	-
Green	CAN High	-
White	CAN Low	-
Yellow	Do Not Connect	-
Braid		-

THNF4x-C	
4 CHANNELS DIGITAL THERMOCOUPLE CONDITIONER 250Hz Sampling Frequency per channel, CAN bus	
Ref:	
SN:	Software version : v

Texys sensors are designed for data recording. If the user wants to include this sensor in a close loop system or active control, he must assume all responsibility.

Range	-100 min, 1800 max	°C
Type	B, E, J, K, N, R, S, T	
Sampling frequency per channel	250	Hz
Sampling error	0.2	%FS max
Cold junction error	± 0.25	°C
CAN bus	2.0A	
CAN bus termination	R=120Ω, Switchable via CAN Bus	
Digital Output	Data Format	2 bytes per cell (signed int)
	Resolution	0.1 °/bit
	Accuracy	± 0.5 °C
Supply Voltage	6 to 25	V
Supply Current	< 25	mA
Calibrator	Calog Temperature	
Dimension	92.7x16x22	mm
Material	Aluminum	
Weight	65	g
Protection	IP53	
Vibration test	20Gpp5'	
Shock	500	G
Operating Temp	-40 to +125	°C
Storage Temp	-40 to +125	°C

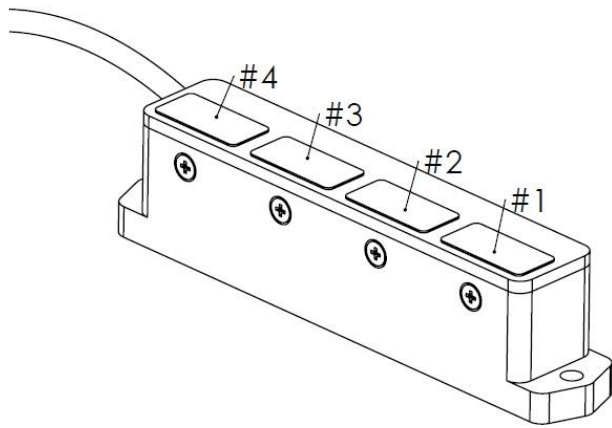
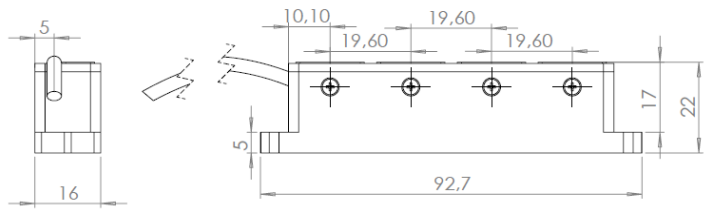

Ordering ref:

THNF4x-C- Type	Range
K	-20+200
J	-40+400
T	0+1800
...	...

Ex: THNF4x-C-K-50+250 → type K, -50 to +250°C

CAN Data output

Tx1 ID 0x3F0	Byte 0 MSB	Byte 1 LSB	Byte 2 MSB	Byte 3 LSB	Byte 4 MSB	Byte 5 LSB	Byte 6 MSB	Byte 7 LSB
	Temperature 1		Temperature 2		Temperature 3		Temperature 4	
	Resolution: 0.1°/bit		Resolution: 0.1°/bit		Resolution: 0.1°/bit		Resolution: 0.1°/bit	

Changing parameters

Must be setup according to Texense's CAN protocol, or by using the Texense Android Smart Tool (tAST®) with your android device. Contact us at info@texense.com

CAN parameters

Address	Parameter	Raw values	values	Comments
0x00	Baudrate	0x00	CAN2.0A 1Mbps	Default
		0x01	CAN2.0A 500 Kbps	
		0x02	CAN2.0A 250 Kbps	
		0x03	CAN2.0A 125 Kbps	
0x01	Emission frequency	0x00	Rx frame trig	Triggering mode - 125Hz max.
		0x01	1 Hz	
		0x02	10 Hz	
		0x03	50 Hz	Default
		0x04	100 Hz	
		0x05	250 Hz	
0x02	Rx frame ID	0 to 0x7F0	MSB	Default 0x07F0
0x03			LSB	
0x04	Tx1 frame ID	0 to 0x7F0	MSB	Default 0x03F0
0x05			LSB	
0x06	Unused	Unused		Reserved
0x07				

Digital Input parameters

0x08	Degree	0	Fahrenheit	Default
		1	Celsius	
0x09	CAN Bus Termination Resistor	0	Not connected	Default
		1	Connected	

For complete information, contact us at info@texense.com