

MATING FEF.

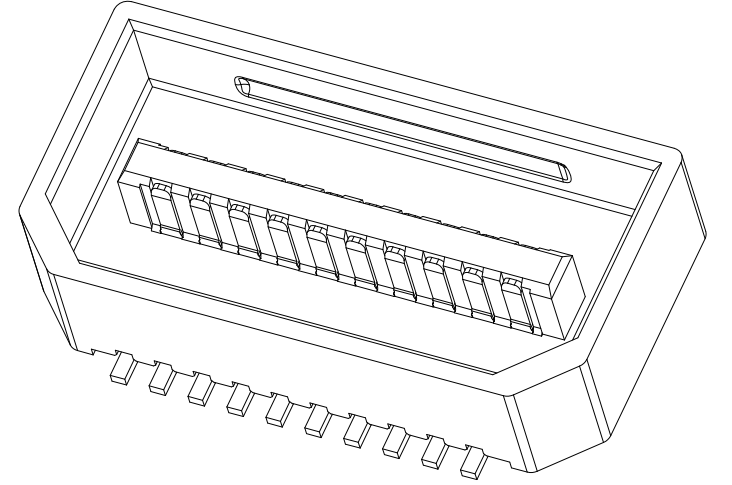

NOTE:
 1.ELECTRICAL REQUIREMENTS
 RATED VOLTAGE: 60V AC/DC
 RATED CURRENT: 0.5A
 CONTACT RESISTANCE: 60 mΩ max.
 INSULATION RESISTANCE: INITIAL VALUE OF 1000 MΩ min./500VDC
 INSULATION VOLTAGE: 250V AC FOR 1 MINUTE
 2.ENVIRONMENTAL REQUIREMENTS
 OPERATING TEMPERATURE: -55 °C ~+85°C
 3.MATERIALS:
 CONTACT: COPPER ALLOY
 PLATING:
 UNDERPLATING:50μ”NICKEL
 CONTACT AREA:8μ”GOLD
 SOLDER TAILS:GOLD FLASH
 HOUSING:HIGH TEMP THERMO PLASTIC UL94V-0

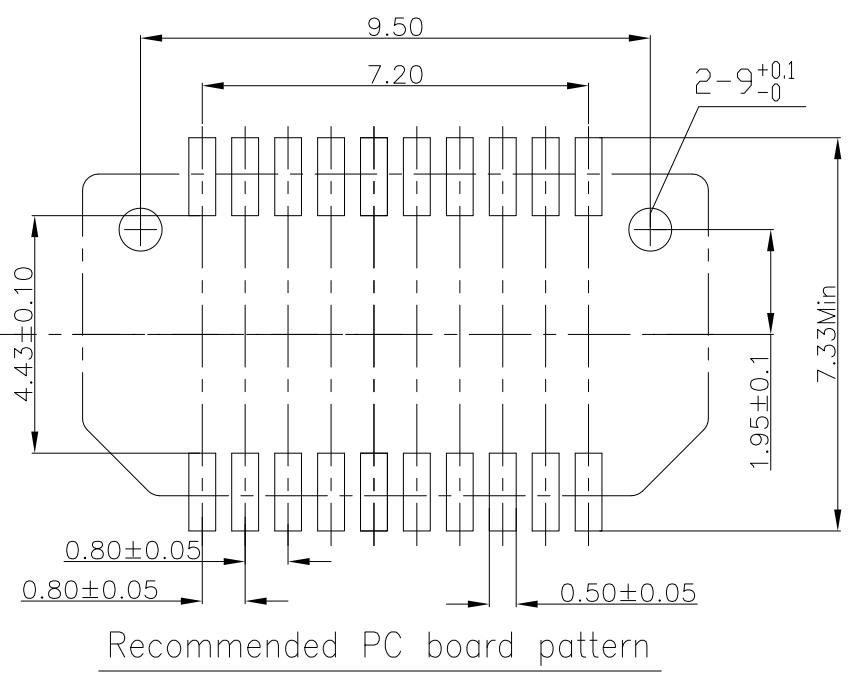

Ordering Information

BS08- 2020 M 1 B 1-474

0.8P Board to Board Single Slot
 2 Rows
 20 Pin
 Terminal Plated B:Gold 8u”
 Packaging 1:Reel
 0: w/o Post
 1: w/ Post
 M: MALE

REV.	REVISION RECORD	DATE	General Tolerance LINEAR 0.0 ±0.35 ANGLE ±3° 0.00 ±0.20		
A	Original	08/18/21		UNIT:mm	
			A4	NAME	TITLE: 0.8P Board to Board Plug SMT Vertical 2.72H
			APPROVED	WENNY	DWG.NO:BS08-2020M1B1-474
			DESIGNER	GRACE	REV. A
			DRAWN	SIATOR	SCALE 1 : 1 SHEET 1 OF 1