

The Eaton logo is displayed in white, bold, sans-serif font. The letter 'O' is stylized with a solid black circle in the center. The background of the top section of the page is a close-up photograph of a large, industrial-grade circuit breaker assembly, showing multiple metal contacts and insulators.

Heinemann Hydraulic-Magnetic Circuit Breakers

Product Focus





Over 100 Years of Excellence

Contents

History	3
Application Information	4 – 5
Technical Data	6 – 9
Product Families	10 – 13
Frame Information	14 – 35
KD Series	14
PROPAK Series	15
J Series	16 – 17
SPHM Series	18 – 19
AMR Series	20 – 23
C Series	24 – 25
GH Series	26 – 27
AM1P Series	28 – 29
GJ Series	30 – 31
GJ1P Series	32 – 33
Special Applications	34 – 35

History

In 1888, George Heinemann founded Heinemann Electric, one of the first electrical contracting companies in the nation. If you lived in the Philadelphia area and you needed repairs on electric lights, you called Heinemann.

In 1915, the Heinemann Electric company withdrew from the contracting business and concentrated on researching electrical protective devices. In 1927, Heinemann developed an automatic protective device called a circuit breaker, and in 1930, Heinemann produced the first magnetic circuit breaker.

Until then, circuit breakers depended on the heat caused by an electrical overload to trip the circuit open. Too often, breakers tripped unnecessarily, such as on a hot day or when installed near heat-generating machinery. A magnetic breaker trips when the magnetic field within a breaker increases due to increased current flow caused by the overload. Heat plays no part in this operation, putting an end to heat-induced nuisance tripping.

During the early 1940s, Heinemann circuit breakers went to war. Widespread use of electronic equipment in World War II, such as radio and radar, led to the installation of Heinemann circuit breakers in every kind of fighting ship from PT boats to battleships, with expanding use to airplanes, radar stations and communication centers.

This led to Heinemann's advance into the growing industrial and consumer electronics market. Heinemann established foreign affiliates to support the demands and progression into the global market.

Today

Heinemann remains the leading manufacturer of OEM circuit breakers, and as part of the Eaton family of brands, Heinemann® shares rich history in circuit protection technology. As Heinemann developed the first hydraulic-magnetic circuit breaker in 1932, Eaton's Cutler-Hammer® brand developed the first molded case circuit breaker in 1928.

Today, we've combined Heinemann and Cutler-Hammer technologies to give customers the best protective solutions available in the world from 12 to 38,000 volts. Heinemann offers product designers the broadest ranges of hydraulic magnetic circuit breakers from 0.1 to 1200 amperes.

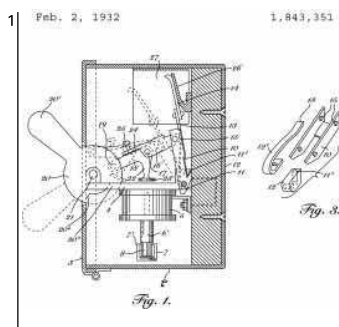

1. First Magnetic Circuit Breaker Design Patent

Application Information

You Have a Choice in Protection



Hydraulic-Magnetic

- Precision Custom Calibration
- Requires No Derating (100% Rated)
- Ambient Compensating (-40°C to +85°C)
- Immediate Reset After Fault
- Broad Range of Integral Internal Accessories
- Provides Equipment and Wire Protection



Fuse Protection

- No-Reset Capability
- Fuses Degrade Over Time
- Protection Effected by Ambient Temperature
- Requires More Panel Space
- No Accessories Available
- Provides Equipment and Wire Protection



Thermal-Magnetic

- Fixed Calibration Band, Wide Variation
- Device Must be Derated to 80% Load
- Protection Effected by Ambient Temperature
- Requires "Cooling-Off" Period
- Accessories in Multi-Pole Devices Only
- Provides Basic Wire Protection

Nuisance Tripping Eliminated

Heinemann hydraulic-magnetic circuit breakers offer three major advantages:

- *Elimination of nuisance tripping* caused by high ambient temperatures in or near the installation. The breaker responds only to current variations, not to temperature change.
- *Continuous operation at 100% current.* There is no such assurance with a thermal device, which may fail to carry rated current when subjected to above normal ambient temperatures. A Heinemann breaker rated at 20 amperes, for example, will sustain 20 amperes, even at elevated temperatures. Derating and other forms of temperature compensation are unnecessary.
- *Immediate reset.* Since there are no thermal elements, heat build-up is not a factor. Therefore, no "cooling off" period is required after a fault.

Guaranteed Power Availability

Using a controlled time delay, Heinemann circuit breakers can eliminate nuisance tripping caused by transient current surges. In any installation where a power supply or compressor motor is on the line, an inrush of current occurs when the equipment is first turned on. The bigger the equipment, the larger the surge. Although inrush surges are, in fact, transient overloads, they usually pose no threat of damage to the line or the equipment. So, it's simply not necessary or even desirable to interrupt the power when they occur.

The hydraulically controlled time-delay mechanism of a Heinemann breaker eliminates nuisance tripping without reducing the overload protection. The delay is inversely proportional to the overload; response is quicker on large overloads where greater potential danger exists, and slower on small overloads. For sensitive electronic equipment, Heinemann breakers can be purchased with an instantaneous trip feature to prevent damage.

Precision Protection

The current rating of the hydraulic-magnetic circuit breaker is determined by the number of wire turns in the load sensing coil. By altering the number of turns and the wire size, Heinemann can provide a breaker of virtually any rating within the unit's overall current carrying range. Regardless of your needs, we can deliver custom equipment protection, even at fractional amperages.

Shock and Vibration

A precision, counterbalanced armature design prevents mechanical tripping due to shock and vibration. This makes the Heinemann family of products perfect anywhere shock and vibration are a concern. Some popular applications include railcars, mobile industrial equipment, generators and marine power distribution.

Global Ready

Heinemann breakers are tested to meet global certifications and standards including UL®, CE, VDE, TUV and CSA®.

Mission Control

With a variety of control and indicating options, the Heinemann line of circuit breakers allows you to take control of your complex operations. Available with integral remote trip coils and indicating contacts, Heinemann breakers can be integrated into your control logic. We also offer a lighted handle design that can allow operators to see breaker conditions at a distance.

Self-Adjusting

The time delay feature is self-adjusting to ambient temperature conditions. At high ambients where the overload tolerance of most circuits is lowered, the viscosity of the fluid in the breaker's dashpot is lessened, and the time delay is thereby shortened. At low temperatures, the response is correspondingly longer to allow for cold equipment startups.

A Look Inside

1. Broad Selection of Terminal Styles

Pressure connector, threaded stud, hook, bus, plug-in and quick-connect terminals (with holes for optional soldering) are available.

2. Self-Cleaning Contacts

Sliding pivot point causes a wiping action across the contacts each time a breaker is switched. This cleaning motion helps keep surface resistance low, extending contact life. (Contacts are made of silver alloy for minimal wattage loss.)

3. Efficient Blowout Grid

U-shaped grid plates quickly draw out, fragment and extinguish contact arc. Charring and pitting are minimized.

4. Sturdy Toggle and Latch

Strong, durable and highly efficient. Latch is shock-resistant, yet provides very fast operation. Trip-free construction makes it impossible to hold the breaker closed against a fault. (Even when handle is held in ON position, contacts trip free of fault condition.)

5. Balanced Armature

Counterbalanced armature design helps prevent mechanical tripping caused by shock and vibration. Meets MIL-STD-202 requirements.

6. Two-Position Switching

Two handle positions, ON and OFF (no ambiguous "reset" position). After fault clearance, simply snap the handle back to ON.

7. Load-Sensing Coil

Magnetic unit measures current, not temperature, making it unnecessary to derate for high-ambient service. Coil will carry 100% rated load as specified in the appropriate response curve.

8. Fungus-Resistant Case

Circuit breakers are housed in special plastic casings that significantly reduce fungal growth and contamination.

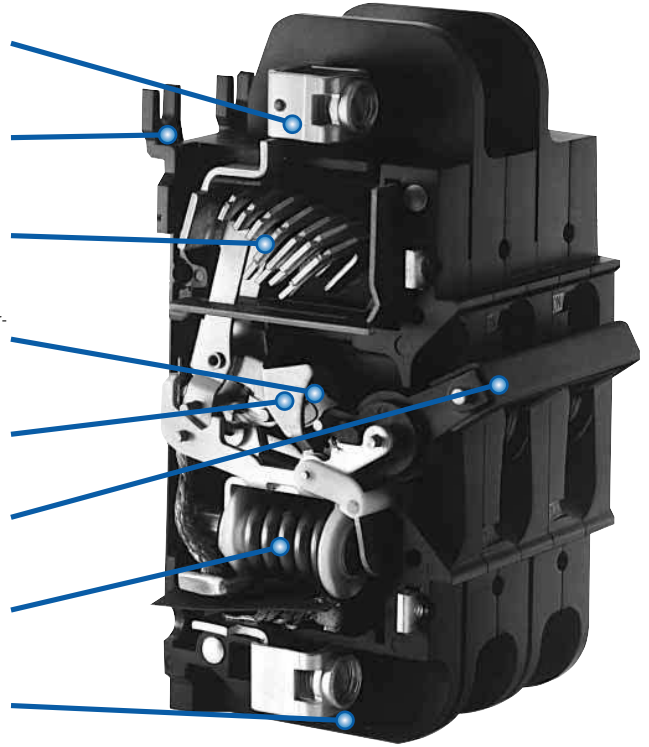

The Hydraulic Principal

The hydraulic-magnetic technology used in the Heinemann line of circuit breakers delivers precision protection and a controlled response to changes in load current. Utilizing a coil of wire to measure the magnetic flux produced in the circuit, in combination with the dampening effect of an oil-filled tube, Heinemann circuit breakers provide reliable, consistent protection characteristics in all environments.

The Heinemann hydraulic-magnetic circuit breaker operates on load-current produced magnetic flux variation in a solenoid. The coil is wound around a hermetically sealed, non-magnetic tube containing a spring-loaded, moveable iron core and a silicone liquid fill. With the load current either at or below the breaker's nominal rating, the magnetic flux is of insufficient strength to move the core, and it remains at the end of the tube opposite the armature.

On an overload, the magnetic flux force increases, pulling the iron core into the coil toward the armature end of the tube. This core insertion reduces the reluctance of the magnetic circuit and further increases the strength of the magnetic field. The silicone liquid regulates the core's speed of travel, creating a controlled trip delay that is inversely proportional to the magnitude of the overload. If the overload subsides before the core reaches the pole piece, the core returns to its original position, and the breaker does not trip. (For non-delay applications, the breaker is modified to omit the intentional delay.)

When the magnetic flux reaches a predetermined value, the armature is attracted to the pole piece and the breaker trips. (The breaker may trip before the core reaches the pole piece if the critical flux value is achieved first.) On very heavy overloads or short circuits, the flux produced by the coil above, regardless of core position, is sufficient to pull in the armature. This circuit interruption occurs with no intentional delay — a highly desirable response characteristic.



Technical Data

Personalized Protection to Fit Your Application

With advanced hydraulic-magnetic technology, we're able to match our breaker performance to meet your exact application requirements. Whether you choose a standard curve, or one of our special application curves, we're sure to have a device that meets your needs. In addition, if you have specific requirements that can't be met with one of our off-the-shelf products, we can custom configure a breaker to protect your equipment.

To find out more about custom breaker solutions, or for application assistance, you can contact our Technical Resource Center at 1-800-356-1243 or via email at trc@eaton.com.

Time Delay Curves and Typical Applications

The curves shown indicate the magnitude and duration of overloads, which will be tolerated before tripping occurs. By selecting the proper curve, breaker response can be closely matched to safe operating limits of the equipment or circuitry. The following are standard curves for typical applications on ac and dc circuits.

Curve 1

Allows the largest and most prolonged overload needed to prevent nuisance tripping on motor circuits.

Curve 2

A medium delay accommodates mixed loads consisting of lights, motors and resistive heating, where the breaker is rated to the wiring instead of to any specific load.

Curve 3

Permits a very brief time delay before tripping and is used for protection of transformers and electronic circuits.

Curve P

Non-time-delay breakers have no deliberately imposed delay and will trip instantaneously at any load above 120% of rated current.

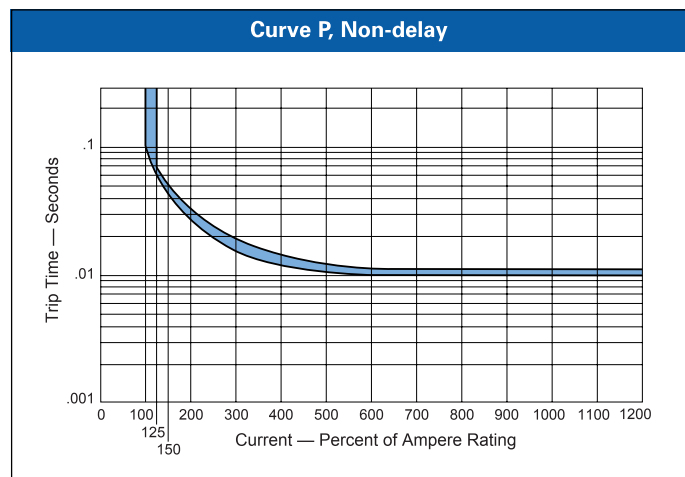
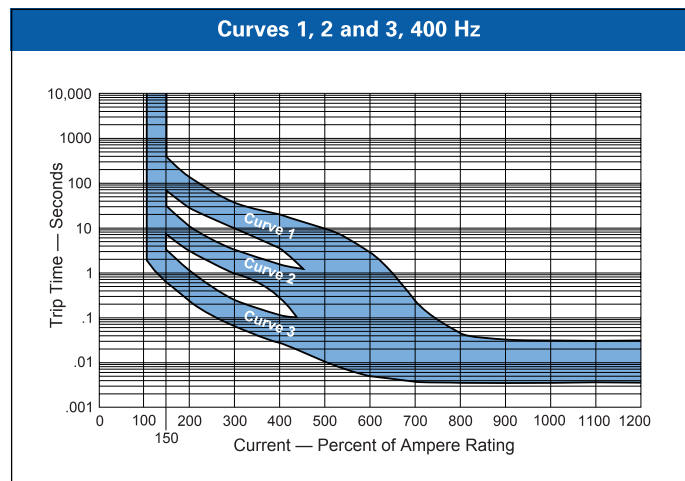
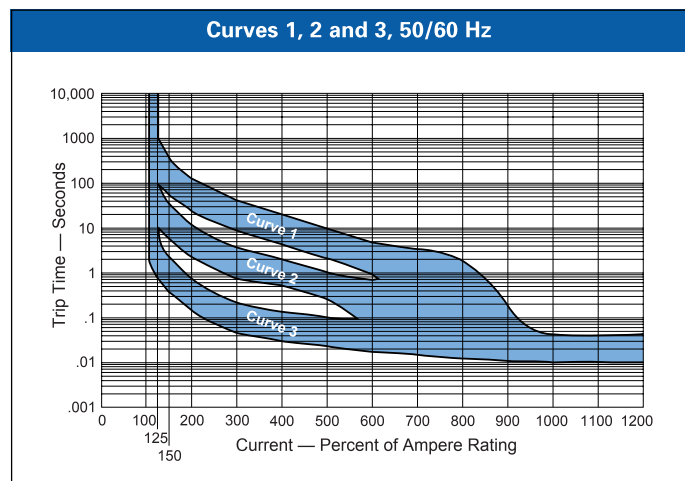
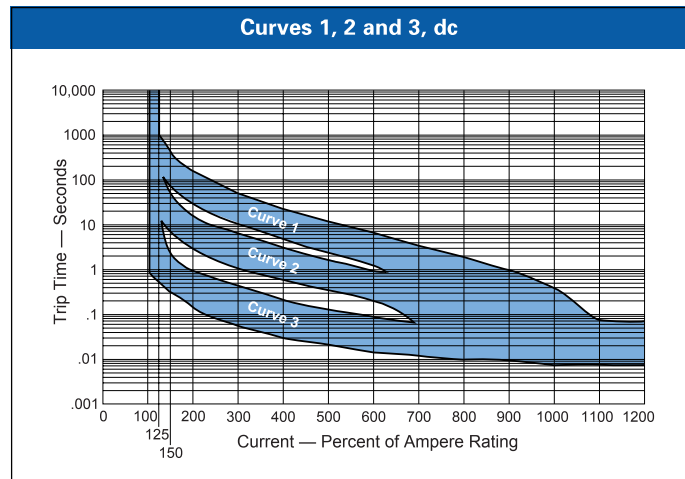

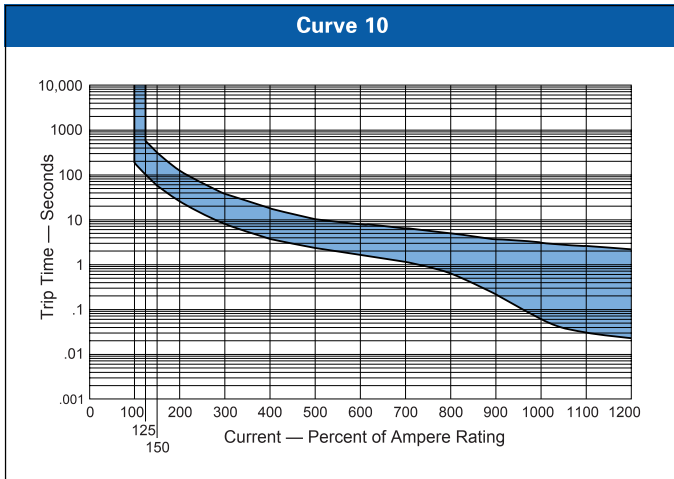

Curve 10

High Inrush — Time delays similar to Curves 1, 2 and 3 with high-inrush surge capabilities.

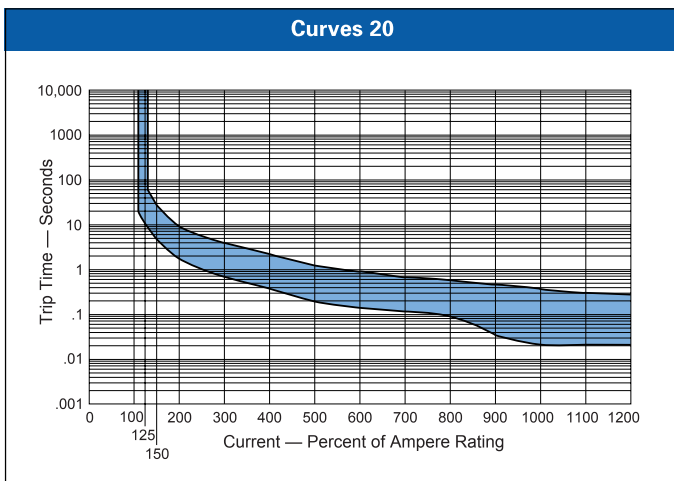

Curve 20

High Inrush — Time delays similar to Curves 1, 2 and 3 with high-inrush surge capabilities.

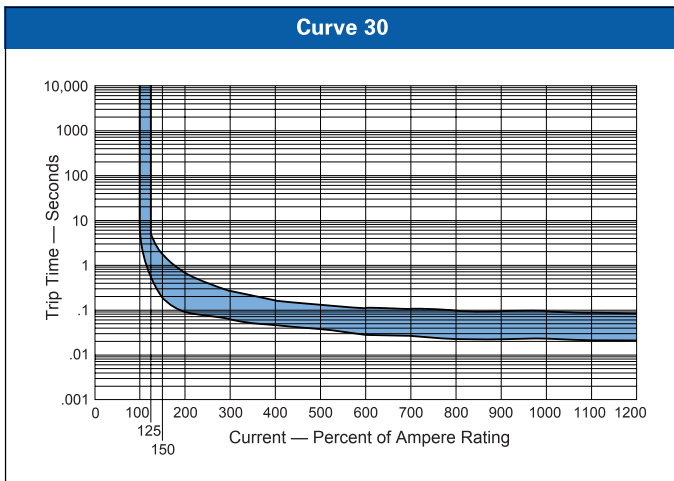

Curve 30

High Inrush — Time delays similar to Curves 1, 2 and 3 with high-inrush surge capabilities.

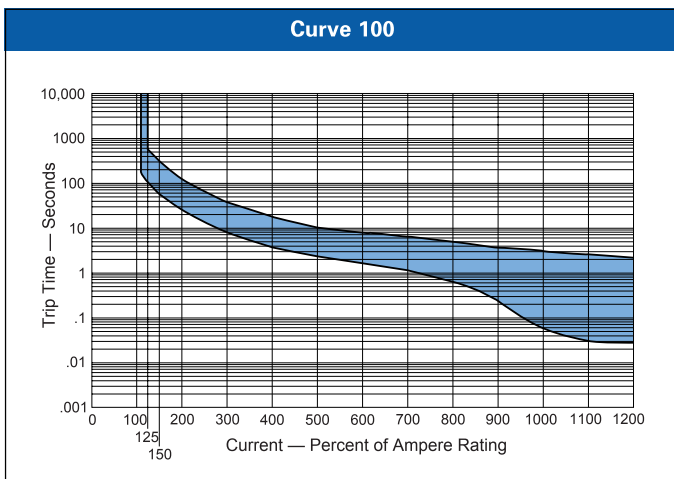

Curve 100

High Inrush — For ferroresonant power supplies, distribution transformers, data processing equipment, etc., which may draw starting surges as high as 3000% normal load. To accommodate brief surges of this magnitude for approximately a half cycle of line current, or 8.3 milliseconds (long enough to get the equipment online without tripping), high inrush models are available.

Specifications

All time-delay curves shown are based on the fact that circuit breakers are not preloaded. (Breakers do not carry current prior to application of overload for calibration testing.) Curves are plotted at an ambient temperature of 77°F (25°C), with breakers in the standard wall-mount position.

Heinemann Breakers are 100% Rated

All circuit breakers shall hold 100% rated load continuously. Time-delay circuit breakers may trip between 101% and 125% of rated load; must trip at 125% and above, as shown on the time-delay curve selected. Breakers rated for ac/dc operation may trip between 101% and 135%; must trip at 135% and above.

Non-time-delay circuit breakers may trip instantaneously between 101% and 120% of rated load; must trip instantaneously at 120% and above.

Ambient Compensating

Time delay will decrease as ambient temperature is raised and increase as ambient is lowered.

Note

These curves are presented for product selection purposes only. For detailed curve information by frame, please visit www.EatonElectrical.com/heinemann.

Technical Data

Heinemann circuit breakers are available in a variety of electrical configurations. When ordering a breaker, you must specify the internal circuit type. Each pole can be configured separately, making the design flexible around your application.

The most common configuration is "Series Trip" which means that the magnetic coil is in series with the main power circuit of the breaker, providing overcurrent protection. By configuring poles separately, you can design equipment that will work in multiple environments.

For instance, by configuring individual poles with different amperage ratings, you could design your equipment to work on different voltages. You could also use the relay trip function to shut down the power circuit while leaving the control circuit energized during a system fault.

Heinemann breakers are ready to meet your demanding application needs.

INTERNAL CIRCUITS

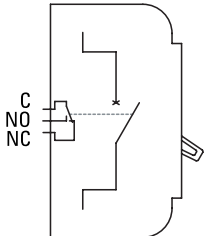
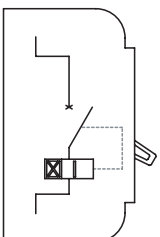
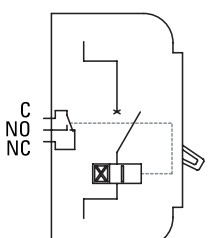
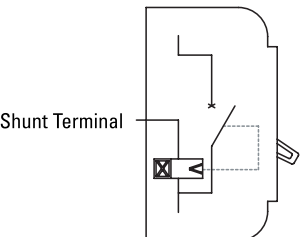
Circuit	Diagram	Description
Switch	Internal Circuits Represented: 0, 12 	Switch only (without coil) with or without auxiliary contact.
Series Trip	Internal Circuits Represented: 3, 8 	The contacts and the coil are in series. It is often used as the main switch.
Series Trip With Auxiliary Contact	Internal Circuits Represented: 2, 9 	The contacts and the coil are in series. Auxiliary contacts are placed behind the circuit breaker and mechanically connected to the releasing system.
Shunt Tap	Internal Circuit Represented: 5 	Enables two loads to be checked by means of a single circuit breaker. However, it only releases if there is an overload in the main circuit. The sum of the two nominal currents must not exceed the peak current of the contacts. With this execution, it is also possible to adjust the tripping through a potentiometer between the load terminals.

INTERNAL CIRCUITS (CONTINUED)

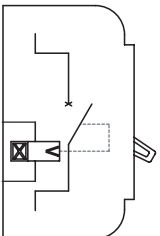
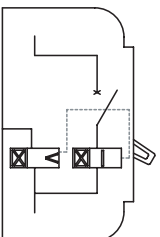
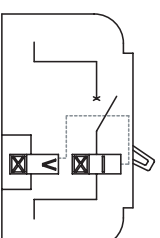
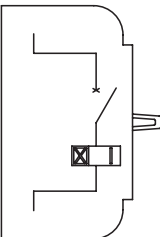
Circuit	Diagram	Description
Relay Trip Relay Terminals	Internal Circuit Represented: 6 	Relay tripping can be used for releasing the circuit breaker by the intermediary of a monitor or a safety device installed at a distance. The contacts are electrically separated from the coil. Consequently, all the currents and voltages within the permissible limits can be used. Coils are either current or voltage sensitive.
Dual Control (DUCON) Shunt Terminal	Internal Circuits Represented: 15, 25 	The version is used both for the protection of the load finding itself in series with the circuit breaker and for the release via a voltage. The main coil is in series with the contact and the DUCON coil is shunt trip.
Dual Control DUCON (Series + Relay) Relay Terminals	Internal Circuits Represented: 16, 26 	Dual Control DUCON allows separate control of the shunt trip coil when the load is not energized. Similar to a shunt trip coil in a molded case breaker.
Mid-Trip	Internal Circuit Represented: 98 	Series overload, mid-trip handle position.

Product Families

KD Series



TECHNOLOGY	POLES	VOLTAGE	CURRENT	INT. CAPACITY
Thermal	1	250 Vac	0.25 – 20 A	1 kA
		32 Vdc	0.25 – 15 A	0.2 kA
		50 Vdc	0.25 – 10 A	0.2 kA

A low-cost pushbutton supplementary protector for electrical equipment. Designed to fit a standard 5/8" round or "D" shaped panel cutout. With a variety of accessories, the KD Series is a perfect replacement for traditional panel-mounted fuse holders.

PROPAK Series



TECHNOLOGY	POLES	VOLTAGE	CURRENT	INT. CAPACITY
Hydraulic	1	250 Vac	0.1 – 20 A	1 kA
Magnetic	2	50 Vdc	0.1 – 20 A	1 kA
		72 Vdc	0.1 – 20 A	1 kA

Miniature single- or 2-pole circuit breaker available with paddle or rocker handle. Available with or without illumination and a variety of internal accessories including auxiliary switches and remote tripping options. Carries UL 1077, CSA and VDE approvals.

J Series



TECHNOLOGY	POLES	VOLTAGE	CURRENT	INT. CAPACITY
Hydraulic	1	125 Vac	0.2 – 50 A	1 kA ¹
Magnetic	2	250 Vac	0.1 – 50 A	5 kA ¹
		415 Vac	0.1 – 30 A	1.5 kA ¹
	4	32 Vdc	0.1 – 50 A	5 kA
		72 Vdc	0.1 – 30 A	2 kA
		80 Vdc	0.1 – 20 A	1 kA

¹ With series fuse.

Small lightweight hydraulic-magnetic circuit breaker perfect for telecom and marine applications. Available in ratings from 0.1 – 50 amperes, the J Series offers a variety of options including snap-in mounting and rocker style handles. The compact size of the J Series makes it well suited for applications where space comes at a premium.

SPHM Series



TECHNOLOGY	POLES	VOLTAGE	CURRENT	INT. CAPACITY
Hydraulic	1	250 Vac	0.1 – 63 A	5 kA
Magnetic	2	480/277 Vac	0.1 – 30 A	3 kA
		80 Vdc	0.1 – 63 A	5 kA
	4			

The SPHM Series Circuit Breaker snaps easily onto a standard 35 mm DIN rail. This saves valuable installation time. Available with a wide range of accessories, the SPHM Series is the perfect alternative to DIN-rail mounted fuse blocks.

AMR Series



TECHNOLOGY	POLES	VOLTAGE	CURRENT	INT. CAPACITY
Hydraulic	1	120/240 Vac	0.2 – 30 A	10 kA ²
Magnetic	2	250 Vac	0.1 – 100 A	3 kA ²
		277 Vac	0.2 – 20 A	10 kA ³
	4	480 Vac	0.1 – 30 A	3 kA ³
		80 Vdc	0.1 – 100 A	5 kA
		125 Vdc	0.1 – 100 A	5 kA

² 5 kA with series fuse.

³ With series fuse.

Ultra-high interrupting circuit breaker for single- or multi-pole applications. The AMR Series delivers significant performance advantages in a compact package. Available as a UL 489 listed device, suitable for branch circuit protection, the AMR can be used in a wide variety of applications, including lighting and power distribution equipment. Also carries UL 1077, CSA and TUV approvals.

C Series



TECHNOLOGY	POLES	VOLTAGE	CURRENT	INT. CAPACITY
Hydraulic	1	240 Vac	1 – 100 A	5 kA
Magnetic	2	480 Vac	0.1 – 100 A	Up to 10 kA ①
	3	600 Vac	0.1 – 77 A	Up to 10 kA ①
	4	125 Vdc	0.1 – 100 A	5 kA

① With series fuse.

High-current circuit breaker for single- or multi-pole applications, the C Series is one of Eaton's most versatile breakers. With a 600 Vac rating and the ability to select from a variety of trip curves, the C Series is an alternative to thermal-magnetic breakers in harsh environments or when precision is essential.

GH Series



TECHNOLOGY	POLES	VOLTAGE	CURRENT	INT. CAPACITY
Hydraulic	1	480 Vac	0.5 – 100 A	14 kA
Magnetic	2	250 Vdc	0.5 – 100 A	14 kA
	3			

The GH Series offers all of the advantages of a completely magnetic 3-pole breaker with a 14,000 ampere interrupting capacity. Perfect for applications in extreme environments where thermal-magnetic breakers would have otherwise been selected. The GH breaker is UL listed (489/508) for branch circuit applications.

AM1P Series



TECHNOLOGY	POLES	VOLTAGE	CURRENT	INT. CAPACITY
Hydraulic	Multiple	80 Vdc	100 – 250 A	up to 50 kA
Magnetic				

The AM1P breaker is designed for telecommunication sites with high current demands and limited space. With a 250 ampere current carrying capacity and improved interrupting ratings up to 50 kA, the AM1P breaker gives unparalleled performance in site applications. The AM1P series is UL 489A listed.

GJ Series



TECHNOLOGY	POLES	VOLTAGE	CURRENT	INT. CAPACITY
Hydraulic	1	250 Vac	0.5 – 250 A	10 kA
Magnetic	2	250 Vdc	0.5 – 250 A	10 kA
	3			

High-current circuit breakers in a compact package, the GJ Series offers protection up to 250 amperes. Add the precision of hydraulic-magnetic protection on your critical loads over 100 amperes.

GJ1P Series



TECHNOLOGY	POLES	VOLTAGE	CURRENT	INT. CAPACITY
Hydraulic	1	65 Vac	100 – 1200 A	25 kA
Magnetic	2	160 Vdc	100 – 1200 A	10 kA
	3			

Similar to the GJ, the GJ1P Series has increased capacity and is available in current ratings up to 1200 amperes. The GJ1P is a UL 489 listed device delivering superior performance.

Product Families

We've assembled a variety of tools to help you select the correct Heinemann Circuit Breaker to fit your needs. The following catalog gives detailed information on each of the breaker frames, but if you require more information, we're here to help 24/7.

Over 2,300 distributor locations worldwide offer local support. Visit us online at www.EatonElectrical.com/heinemann. For technical support via e-mail, contact trc@eaton.com or call 1-800-356-1243 (U.S. locations) or +41 21 841 18 41 (International).

Eaton Electrical Article

Address: <http://www.eatonelectrical.com/IASApp/cs/ContentServer?pagename=C-H/Common/AssetTemplateLink&c=Apubarticles&cid=1016116310836>

EATON | Electrical

Home | Contact Us | Find Us | Global Sites | Search | Log In | Eaton.com

Products | Solutions & Services | How To Buy | Support | News & Events | Learning | About Us

Home>>Services and Solutions>>Products Home>>Document Search>>Documents and Support

■ Products Home

Products

- Products A-Z
- Vintage Products
- Brand Names
- New Products
- Interactive House *New!*

Search Documents

- Search

Catalogs

- Products & Services
- Consulting Application
- Aftermarket Products
- PAD Digest
- More Catalogs

Curves

- Curves

Drawings/Downloads

- CAD Downloads
- Software Downloads
- All Drawings
- ATS Drawings
- MCC Drawings
- Project Drawings

Hydraulic Magnetic Circuit Breakers

Heinemann hydraulic-magnetic circuit breakers are available in both AC and DC ratings in accordance with UL, CSA and VDE standards. Heinemann offers a number of equipment, branch and main circuit breaker products that meet American, European and Asian agency listings, ensuring products designed with Heinemann may be designed, built and sold worldwide.



The hydraulic-magnetic circuit breakers are available in circuit configurations such as the commonly-used Series Trip; Dual Rating for tripping at two discrete current ratings; Relay Trip for remote trip actuation isolated from the line voltage; and Shunt Tap for remote tripping using the line voltage. An integrated auxiliary switch is available for remote alarm applications. Also available are a variety of screw, stud, clip and plug-in terminal options. Several handle color, marking and location options are also available.

Application

- Propak Series up to 20A
- JS Series up to 50A
- DM Series up to 50A
- CD-CE-CF Series up to 125A
- AM & AM1P Series up to 200A
- GH Series up to 100A
- GJ Series up to 250A
- GJ1P Series up to 1200A

Related Links...

- Propak Series up to 20A
- JS Series up to 50A
- DM Series up to 50A
- GH Series up to 100A
- CD-CE-CF Series up to 125A
- AM/AM1P Series up to 200A
- GJ Series up to 250A
- GJ1P Series up to 1200A

[Send](#) [Printer-friendly Format](#)

[Privacy Policy](#) | [How Can We Improve This Page?](#) | [Terms & Conditions](#)
Copyright © 2001 - 2004 Eaton Electrical Inc.,
All Rights Reserved

Internet zone

Product Quick Selector

Eaton Heinemann provides breakers from 0.1 – 1200 amperes for applications up to 600 Vac or 250 Vdc. Please refer to the selection table at the right to select the frame that will meet your needs. Detailed information for each frame is provided in the following pages. For additional information, or help with product selection, please refer to our contact information listed on **page 12**.

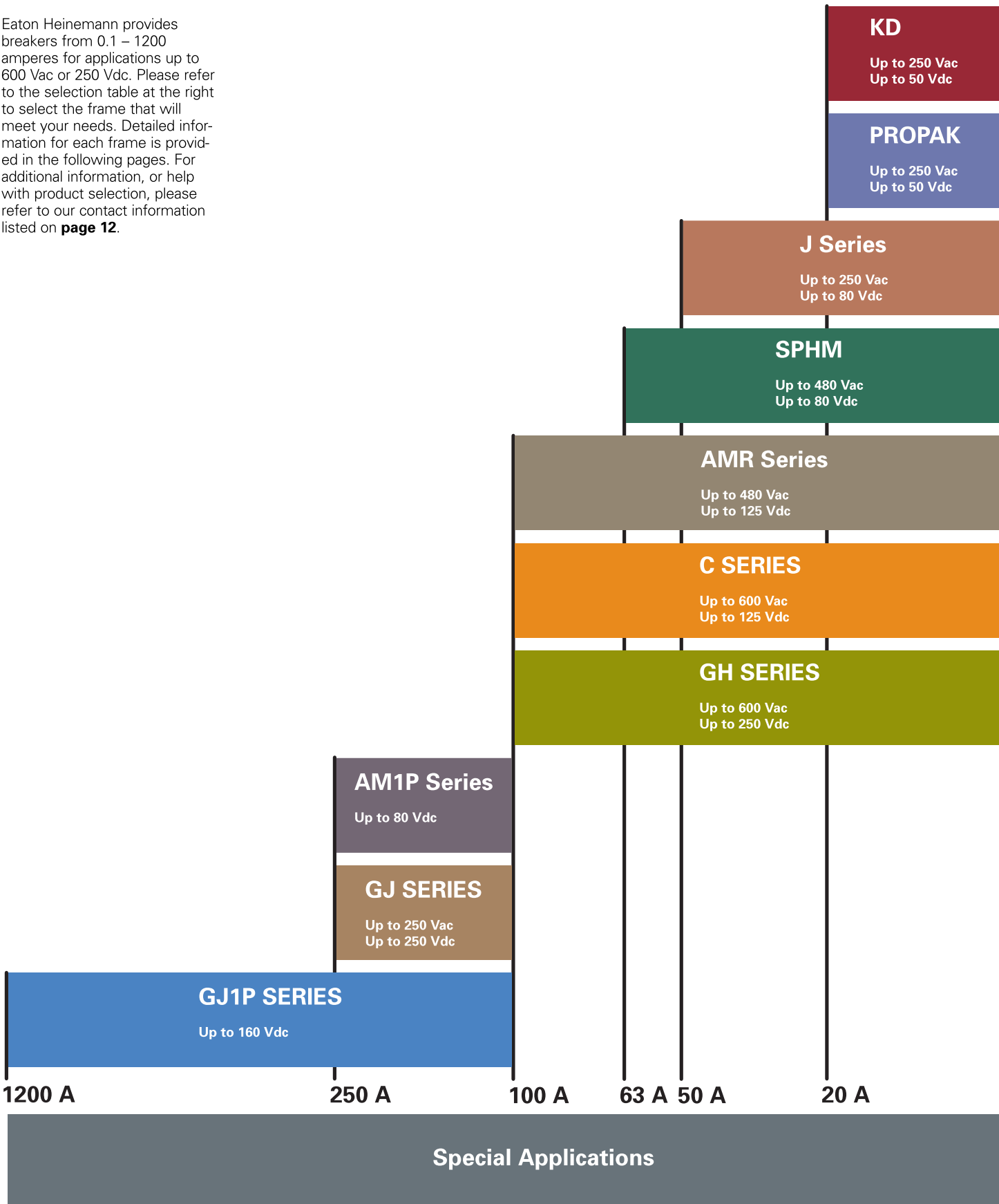

Frame Information

KD Series



KD Series

Resettable Pushbutton Circuit Protector

- Provides basic thermal protection.
- Ratings from 0.25 – 20 amperes.
- UL recognized.

The KD Pushbutton Circuit Protector provides circuit protection similar to a fuse but does not require replacement after a fault. This resettable design allows your customer to stay online and eliminate downtime.

Easy Installation

The KD Series is easily installed in a 5/8" round or D-Shaped panel cutout similar to that used on conventional panel-mounted fuse holders. It can be mounted from either the front or rear and is held in place by special hardware. Its 1/4" quick-connect terminals are solderable.

Industry Approvals

The KD Series has been tested to meet the requirements of UL 1077, and is recognized as a supplemental protector by UL. We also carry CSA approval for applications in Canada.

Positive Action

The KD Pushbutton Circuit Protector trips without delay on short circuit, and with a controlled delay upon sustained overloads upon tripping, the contacts open with a positive snap action, thereby suppressing the arc.

Protective Covers

For applications where equipment may be exposed to dust or moisture, protective boots are available. Two styles are available, one which protects the breaker from splashing water and another which seals the panel opening.

To order the slip-on boot, choose Catalog Number 006-10469 or for a panel sealing version, purchase Catalog Number 006-10528.

Standard Product Offering

CURRENT	CATALOG NUMBER
0.25 A	KD1-0R25
0.50 A	KD1-0R50
0.75 A	KD1-0R75
1.00 A	KD1-1
1.50 A	KD1-1R5
1.75 A	KD1-1R75
2.00 A	KD1-2
2.50 A	KD1-2R5
3.00 A	KD1-3
4.00 A	KD1-4
5.00 A	KD1-5
6.00 A	KD1-6
7.00 A	KD1-7
8.00 A	KD1-8
9.00 A	KD1-9
10.00 A	KD1-10
15.00 A	KD1-15
20.00 A	KD1-20

Typical Dimensions

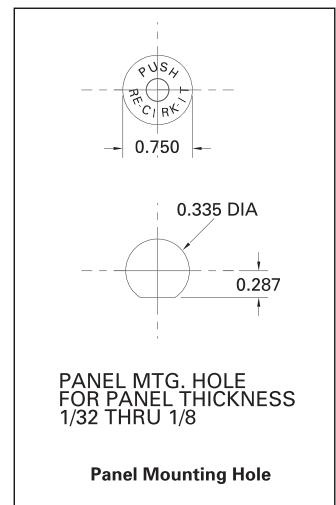
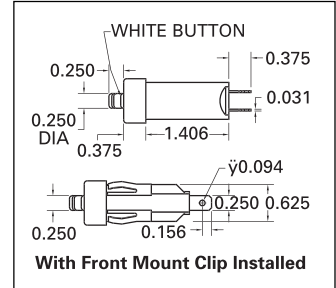

Accessories

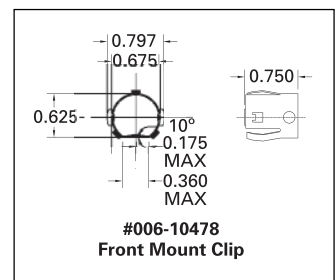
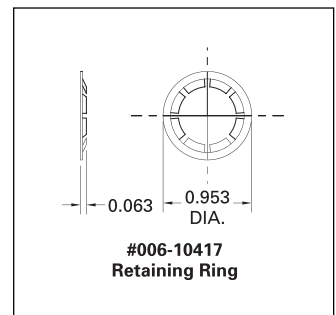

Frame Information

PROPAK Series

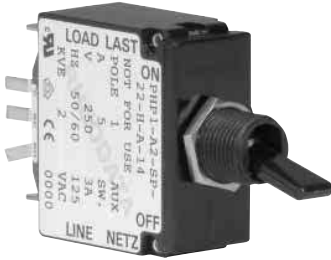

PROPAK Series

Hydraulic-Magnetic Circuit Protector

- 1- or 2-poles.
- 0.1 to 20 amperes.
- Auxiliary switch option.
- Meets MIL-STD for shock, vibration, temperature and humidity.

The PROPAK offers the performance of a hydraulic-magnetic breaker in a miniature package. Available in 1- or 2-pole versions, the PROPAK can be used in a variety of applications up to 250 Vac. All breakers ship with mounting hardware included and have quick-connect terminals for fast installation.

Time Delay Options

Choose from instantaneous or standard time delay curves 2 or 3. A high inrush version is also available.

Approvals

The PROPAK series is UL recognized under UL 1077 and carries CSA approval. Each unit carries an interrupting capacity of 1 kA at maximum voltage of 250 Vac or 72 Vdc.

Accessories

Some popular accessories include optional internal auxiliary contacts and screw terminal adapters.

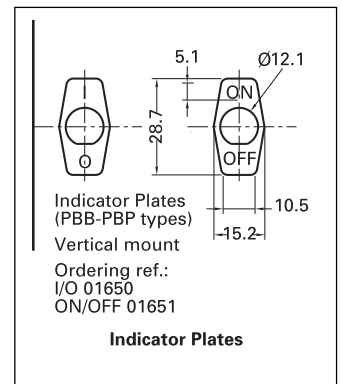
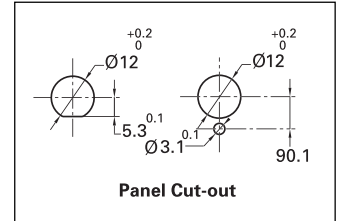
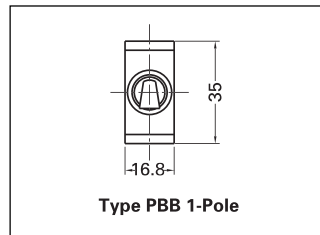
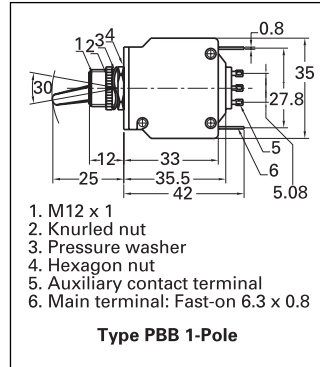

PROPAK SERIES CATALOG NUMBERING SYSTEM

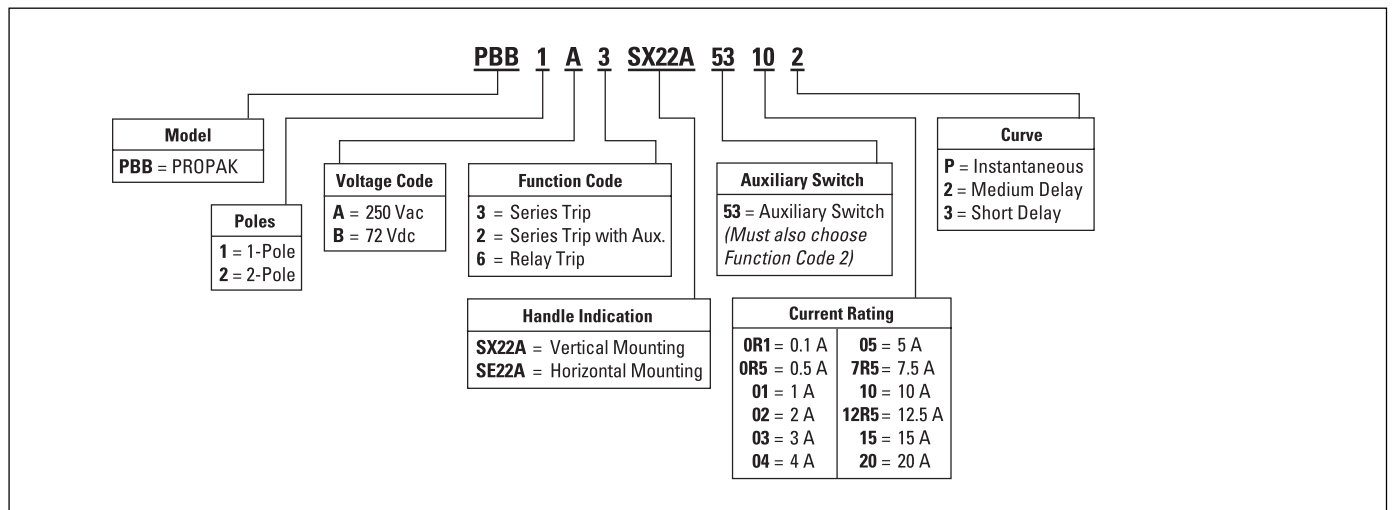

Frame Information

J Series



Standard Style JA



Snap-in Mounting JB



Rocker Style JC



Sealed Toggle JE

Eaton's J Series is one of the most versatile breakers offered in the Heinemann product line. The J Series can be used in a wide variety of applications including telecom, rail, marine and mobile equipment. Multiple mounting and handle configurations allow you to customize your equipment. These include rocker handles, snap-in mounting, sealed toggle actuators and color-coded handles.

Compact Size

The J Series breakers are small and lightweight, saving valuable space in crowded control panels or weight in portable equipment. Since the J Series is magnetically actuated, the breaker generates minimal heat, and breakers can be mounted in densely packed panels with no effect on performance.

Easy Installation

The J Series is designed for fast, easy panel mounting. Its round bezel eliminates square cuts during panel fabrication, and shortens panel production time. Cutout preparation is as simple as punching or drilling three common-center holes per breaker.

Terminals

The J Series is ready to accept either standard push-on or screw terminal connections.

Accessories

Available with integral auxiliary switches, shunt and relay trip options, as well as a variety of external accessories including protective shields and adapter plates.

Global Ready

The J Series is ready for your global applications. In addition to UL 1077, the breaker also carries CSA and IEC 380 approvals.

Harsh Environments

In areas where the breaker may be subjected to water spray or splashing, the J Series is available in a sealed mounting version. Utilizing a molded silicone rubber seal, the exposed handle is protected from the elements when used in conjunction with a sealed panel. For areas requiring a completely sealed breaker, the J Series is also available in a UL 1500 Ignition-Protected Construction. Please refer to the Special Application section of this brochure.

Stock Availability

Standard breaker configurations are available from our regional distribution centers or from one of our 2,300 distributor locations worldwide.

Standard Breaker Configurations

The J Series can be ordered in a number of standard configurations utilizing the table to the right. Once you create your catalog number, you can contact our Technical Resource Center for verification and quotations.

Custom Applications

The J Series is also available in a number of custom configurations to meet your specific application needs. To order a special application breaker, you can visit our Web site at www.EatonElectrical.com/heinemann for a list of custom modifications and information on how to obtain a proprietary catalog number. You may also contact the Technical Resource Center for application information and breaker selection assistance.

Standard Product Offering 250 Vac/65 Vdc Push-on Terminals

POLES	CURRENT	CURVE	CATALOG NUMBER
1	1 A	2	JA1SD3A000102E
1	1 A	3	JA1SD3A000103E
1	2.5 A	2	JA1SD3A02R502E
1	2.5 A	3	JA1SD3A02R503E
1	5 A	2	JA1SD3A000502E
1	5 A	3	JA1SD3A000503E
1	7.5 A	2	JA1SD3A07R502E
1	7.5 A	3	JA1SD3A07R503E
1	10 A	2	JA1SD3A001002E
1	10 A	3	JA1SD3A001003E
1	15 A	2	JA1SD3A001502E
1	15 A	3	JA1SD3A001503E
1	20 A	2	JA1SD3A002002E
1	20 A	3	JA1SD3A002003E
1	25 A	2	JA1SD3A002502E
1	25 A	3	JA1SD3A002503E
1	30 A	2	JA1SD3A003002E
1	30 A	3	JA1SD3A003003E
2	1 A	2	JA2SD3A000102E
2	1 A	3	JA2SD3A000103E
2	2.5 A	2	JA2SD3A02R502E
2	2.5 A	3	JA2SD3A02R503E
2	5 A	2	JA2SD3A000502E
2	5 A	3	JA2SD3A000503E
2	7.5 A	2	JA2SD3A07R502E
2	7.5 A	3	JA2SD3A07R503E
2	10 A	2	JA2SD3A001002E
2	10 A	3	JA2SD3A001003E
2	15 A	2	JA2SD3A001502E
2	15 A	3	JA2SD3A001503E
2	20 A	2	JA2SD3A002002E
2	20 A	3	JA2SD3A002003E
2	25 A	2	JA2SD3A002502E
2	25 A	3	JA2SD3A002503E
2	30 A	2	JA2SD3A003002E
2	30 A	3	JA2SD3A003003E
3	1 A	2	JA3SD3A000102E
3	1 A	3	JA3SD3A000103E
3	2.5 A	2	JA3SD3A02R502E
3	2.5 A	3	JA3SD3A02R503E
3	5 A	2	JA3SD3A000502E
3	5 A	3	JA3SD3A000503E
3	7.5 A	2	JA3SD3A07R502E
3	7.5 A	3	JA3SD3A07R503E
3	10 A	2	JA3SD3A001002E
3	10 A	3	JA3SD3A001003E
3	15 A	2	JA3SD3A001502E
3	15 A	3	JA3SD3A001503E
3	20 A	2	JA3SD3A002002E
3	20 A	3	JA3SD3A002003E
3	25 A	2	JA3SD3A002502E
3	25 A	3	JA3SD3A002503E
3	30 A	2	JA3SD3A003002E
3	30 A	3	JA3SD3A003003E

BASIC DIMENSIONS

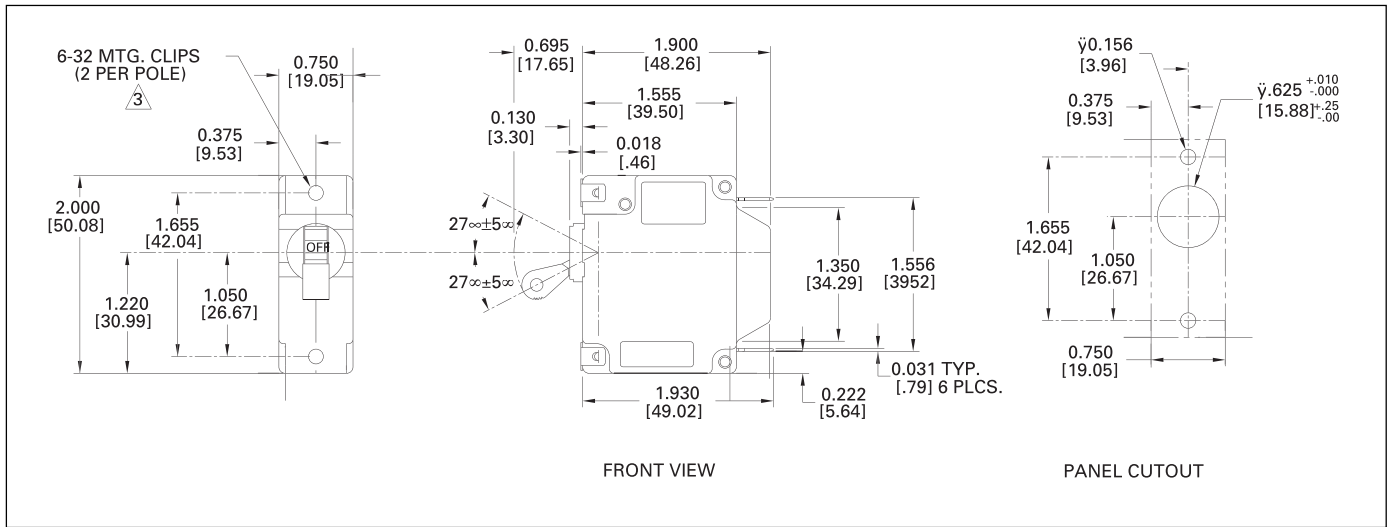

J SERIES CATALOG NUMBERING SYSTEM

JA1S A 3 A 0015 01 E

Style ①	Number of Poles	Description	Handle Color	Mounting
JA_S	1 to 4	Toggle Handle	White ON/OFF	6-32
JB_S	1 to 4	Snap-in Mount	White ON/OFF	N/A
JC_S	1 to 4	Rocker Handle	White ON/OFF	6-32
JE_S	1 to 3	Sealed Toggle	N/A	3/8-32

Voltage, Terminal and Frequency Code			
Code	Frequency	Terminal Location	Maximum Voltage
A	50/60 Hz	Push-on	277 ac
T	50/60 Hz	8-32 Screw	277 ac
K	50/60 Hz	10-32 Screw	277 ac
B	dc	Push-on	65 dc
V	dc	8-32 Screw	65 dc
L	dc	10-32 Screw	65 dc
D	60 Hz/dc	Push-on	250 ac/65 dc
E	60 Hz/dc	8-32 Screw	250 ac/65 dc
R	60 Hz/dc	10-32 Screw	250 ac/65 dc
C	400 Hz	Push-on	250 ac
W	400 Hz	8-32 Screw	250 ac
N	400 Hz	10-32 Screw	250 ac

Approval Code				
A = Up to 250 Vac UL 1077 Up to 65 Vdc UL 1077 L = 277 Vac UL 1077				

Internal Circuit Type and Inrush Catalog Code				
N/A	STD	18X	25X	Internal Circuit
0	—	—	—	Switch Only
—	3	8	38	Series Trip
—	2	9	39	Series Trip w/Aux.
—	5	—	—	Shunt/Tap
—	6	—	—	Relay Trip

Current Rating ②	
Code	Current (Amperes)
0R02	0.02
0R10	0.10
0R25	0.25
0R50	0.50
0R75	0.75
0001	1
02R5	2.5
0005	5
07R5	7.5
0010	10
0015	15
0020	20
0025	25
0030	30
0040	40
0050	50

Voltage Rating	
E = 0 – 250 Vac	
F = 251– 277 Vac	
G = 415 Vac ③	
N = 0 – 65 Vdc	

Time Delay Curve	
0P = Instant	
01 = Long Delay Std. Inrush	
02 = Medium Delay Std. Inrush	
03 = Short Delay Std. Inrush	
10 = Long Delay 18X Inrush	
20 = Medium Delay 18X Inrush	
30 = Short Delay 18X Inrush	
251 = Long Delay 25X Inrush	
252 = Medium Delay 25X Inrush	
253 = Short Delay 25X Inrush	

① Choose style and select from 1 to 4 poles, and enter the number in position 3 of the catalog number. For example, a JA1S would identify a 1-pole JA Series breaker.
 ② Enter the four digit current rating. For example, use code "0015" for a 15 ampere current rating. For fractional amperages, use an "R" to designate the decimal point. For 0.10 ampere, enter the code "0R10."
 ③ Non-standard. Consult technical support 1-800-356-1243.

Frame Information

SPHM Series



The SPHM Series Circuit Breaker line is designed to provide supplementary protection on ac circuits up to 250 volts or stand-alone overcurrent and short-circuit protection on dc circuits up to 80 volts. Recognized by UL and CSA, the SPHM Series has the features required by panel builders and meets the requirements of UL 508A when utilized in control circuits.

SPHM Series Circuit Breakers are DIN-rail mountable for quick installation, and are perfect for a wide range of applications including:

- Motor Control Circuits
- Control Power Transformers
- Relays
- Contactor Coils
- PLC I/O Points

With proven hydraulic-magnetic protection, the SPHM Series Circuit Breaker can be used to provide precision protection regardless of ambient temperature.

Features

Environmental, Vibration and Shock Resistant

Mil-spec qualification for fungus resistance, humidity, salt spray resistance and shock vibration resistance.

Heat-Induced Nuisance Tripping Eliminated

The protector is designed to “hold in” at 100% continuous rated current, regardless of ambient temperatures from -40°C to +85°C.

Immediate Reset After Trip

The protector can be reset (closed) immediately after an overcurrent trip without a “cooling off” period.

1/2 Cycle High Inrush Tolerance — 8X (Standard), 18X and 25X

The protector is available with different levels of tolerance to 1/2 cycle current spikes. Standard tolerance is 8X the continuous current rating; in addition 18X and 25X are also available.

Overcurrent Curves, Long, Medium or Short Delay

Time characteristic curves are available as Short, Medium and Long Delay.

Integral Auxiliary Switch (Optional Selection)

One auxiliary switch (a or b) can be factory installed per pole — a separate pole for auxiliary is NOT required. Contact Eaton for price adder.

Precise Overcurrent Calibration:

The protector can be precisely calibrated to a wide variety of current ratings, from 0.1 to 50 continuous amperes.

DIN-Rail Mountable

The protector can be easily mounted, utilizing its quick release spring clip to attach it to a 35 mm DIN rail.

Standards and Certifications

UL recognized under UL 1077, CSA 22.2, VDE 0660, IEC 60947-2.

Standard Breaker Configurations

The SPHM Series can be ordered in a number of standard configurations utilizing the table to the right. Once you create your catalog number, you can contact our Technical Resource Center for verification and quotations.

Custom Applications

The SPHM Series is also available in a number of custom configurations to meet your specific application needs. To order a special application breaker, you can visit our Web site at www.EatonElectrical.com/heinemann for a list of custom modifications and information on how to obtain a proprietary catalog number. You may also contact the Technical Resource Center for application information and breaker selection assistance.

Standard Product Offering

POLES	CURRENT	CURVE	CATALOG NUMBER
1	0.10 A	2	SPHM1RM00R1
1	0.25 A	2	SPHM1RM0R25
1	0.50 A	2	SPHM1RM0R50
1	0.75 A	2	SPHM1RM0R75
1	1.00 A	2	SPHM1RM0001
1	2.50 A	2	SPHM1RM02R5
1	5.00 A	2	SPHM1RM0005
1	7.50 A	2	SPHM1RM07R5
1	10.0 A	2	SPHM1RM0010
1	15.0 A	2	SPHM1RM0015
1	20.0 A	2	SPHM1RM0020
1	25.0 A	2	SPHM1RM0025
1	30.0 A	2	SPHM1RM0030
1	35.0 A	2	SPHM1RM0035
1	40.0 A	2	SPHM1RM0040
1	50.0 A	2	SPHM1RM0050
2	0.10 A	2	SPHM2RM00R1
2	0.25 A	2	SPHM2RM0R25
2	0.50 A	2	SPHM2RM0R50
2	0.75 A	2	SPHM2RM0R75
2	1.00 A	2	SPHM2RM0001
2	2.50 A	2	SPHM2RM02R5
2	5.00 A	2	SPHM2RM0005
2	7.50 A	2	SPHM2RM07R5
2	10.0 A	2	SPHM2RM0010
2	15.0 A	2	SPHM2RM0015
2	20.0 A	2	SPHM2RM0020
2	25.0 A	2	SPHM2RM0025
2	30.0 A	2	SPHM2RM0030
2	35.0 A	2	SPHM2RM0035
2	40.0 A	2	SPHM2RM0040
2	50.0 A	2	SPHM2RM0050
3	0.10 A	2	SPHM3RM00R1
3	0.25 A	2	SPHM3RM0R25
3	0.50 A	2	SPHM3RM0R50
3	0.75 A	2	SPHM3RM0R75
3	1.00 A	2	SPHM3RM0001
3	2.50 A	2	SPHM3RM02R5
3	5.00 A	2	SPHM3RM0005
3	7.50 A	2	SPHM3RM07R5
3	10.0 A	2	SPHM3RM0010
3	15.0 A	2	SPHM3RM0015
3	20.0 A	2	SPHM3RM0020
3	25.0 A	2	SPHM3RM0025
3	30.0 A	2	SPHM3RM0030
3	35.0 A	2	SPHM3RM0035
3	40.0 A	2	SPHM3RM0040
3	50.0 A	2	SPHM3RM0050

BASIC DIMENSIONS

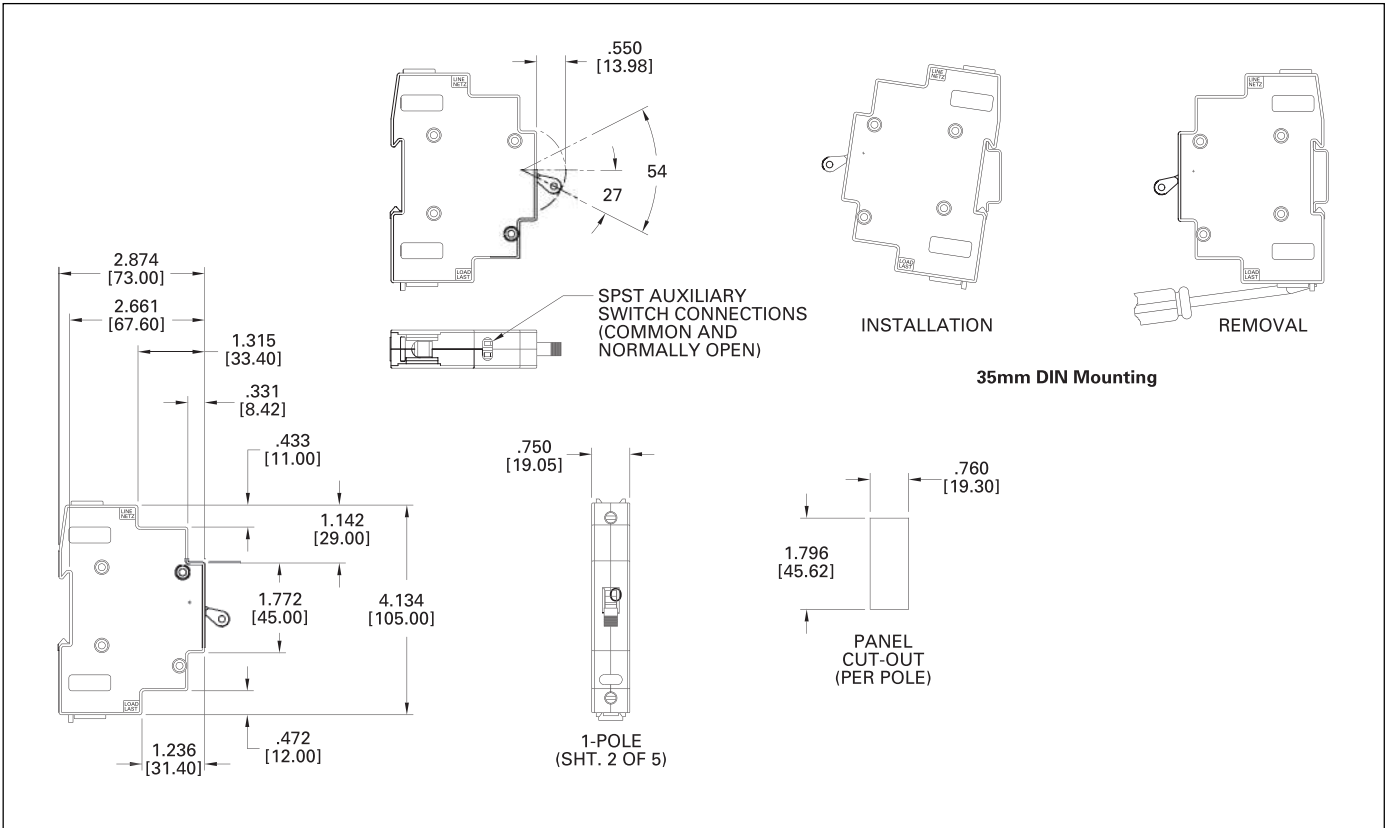

SPHM SERIES CATALOG NUMBERING SYSTEM

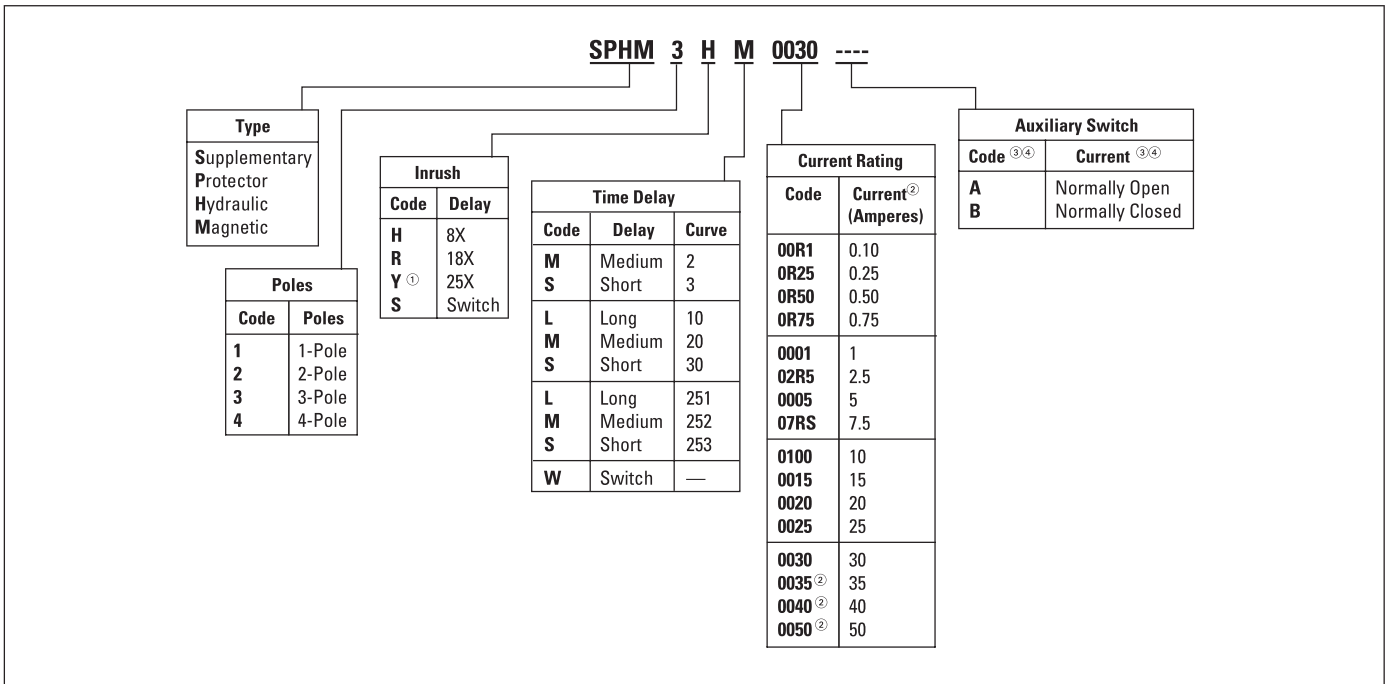

① Maximum of 40 amperes available at 25X inrush.

② UL recognized to 250 Vac, 5 kA above 30 amperes.

③ One A or B contact maximum per pole. Contacts will be arranged left to right (e.g. BAB suffix on 3-pole breaker).

④ Contact Heinemann for availability and price at 1-800-356-1243.

Frame Information

AMR Series



Standard Style (AMR)



Illuminated Style (AML)



Rocker Style (ACR)

The Heinemann AMR Series is the logical choice for applications requiring greater interrupting performance coupled with the sensitivity of hydraulic-magnetic protection. The precisely tailored time delays and ability to interrupt high currents make them ideal for critical applications.

UL 489 Listed

The AMR Series is UL 489 Listed and CSA certified for branch circuit applications. It is also UL 1077 recognized for use in panels where branch circuit protection is already provided. Available in a wide variety of configurations, the AMR Series is rated as high as 100 amperes at 240Vac or 80Vdc. It is the solution for demanding applications requiring up to 50,000 amperes interrupting capacity. The 50,000 amperes interrupting capacity is at 65 Vdc UL 489A, telecom applications.

All UL 489 listed configurations are suitable for normal and reverse feed connection, for easy installation.

UL 489 Ratings

POLES	CURRENT	VOLTAGE	KA
1	0.02 – 100 A	65 Vdc	50
1, 2	0.02 – 50 A	120/240 Vac	10
3	0.02 – 30 A	240 Vac	10
1	0.02 – 20 A	277 Vac	10

Global Design

The AMR Series is designed for global applications, meeting a variety of international standards. It combines the proven high quality and reliability of the former AM Series with the spacing, dielectric and interrupt requirements of the IEC Standard 60947-2. The AMR Series carries the CE Mark, VDE and TUV approvals, and is available with metric hardware for OEMs exporting their equipment overseas.

Features

- Current range up to 100 A 50/60 Hz ac/125 Vdc, 60 A 400 Hz ac.
- 100% rated.
- Plug-in, screw or stud terminals.
- Handles knurled for positive grip.
- Operating temperature -40°C to +85°C.
- Available with internal auxiliary or alarm switch, relay trip function and shunt tap.
- Shock-tested for shock in accordance with MIL-STD-202.
- Vibration-tested in accordance with MIL-STD-202.
- Dielectric strength tested in accordance with MIL-STD-202.
- Insulation resistance of 100 megohms minimum at 500 Vdc, per MIL-STD-202.
- Flammability specifications of UL 94-VO case, UL 94-HB handle.
- Available with UL 1500 Ignition Protected for Marine Applications. Refer to the special applications section for more information.
- Direct replacement for discontinued AM and NAM/S models.

Approvals

- UL 1077 recognized.
- UL 489 listed.
- UL 489A listed for telecom applications.
- IEC 60947-2.
- VDE.
- TUV.

Handle Configurations

Standard Black Toggle

For industrial and commercial applications, where economical design and construction is a concern. Order Prefix "AMR."

Illuminated Toggle

Provides indication of breaker status via the integral multicolored LED. Can be custom configured for indication of ON, OFF, Tripped or Ready status. Order Prefix "AML."

Rocker Style

Used where style and performance is required. The rocker style handle delivers the performance of the AMR Series with European styling. Order Prefix "ACR."

Standard Product Offering

The following catalog numbers can be ordered from stock.

AMR STANDARD BLACK TOGGLE				
CURRENT	CURVE	1-POLE	2-POLE	3-POLE
1.00 A	2	AM1RA3AC07DA12	AM2RA3AC07DA12	AM3RA3AC07DA12
2.50 A	2	AM1RA3AC07DA2R52	AM2RA3AC07DA2R52	AM3RA3AC07DA2R52
5.00 A	2	AM1RA3AC07DA52	AM2RA3AC07DA52	AM3RA3AC07DA52
7.50 A	2	AM1RA3AC07DA7R52	AM2RA3AC07DA7R52	AM3RA3AC07DA7R52
10.0 A	2	AM1RA3AC07DA102	AM2RA3AC07DA102	AM3RA3AC07DA102
15.0 A	2	AM1RA3AC07DA152	AM2RA3AC07DA152	AM3RA3AC07DA152
20.0 A	2	AM1RA3AC07DA202	AM2RA3AC07DA202	AM3RA3AC07DA202
30.0 A	2	AM1RA3AC07DA302	AM2RA3AC07DA302	AM3RA3AC07DA302
50.0 A	2	AM1RA3AC07DA502	AM2RA3AC07DA502	AM3RA3AC07DA502
80.0 A	2	AM1RA3AC97DA802	AM2RA3AC97DA802	AM3RA3AC97DA802

TYPICAL DIMENSIONS

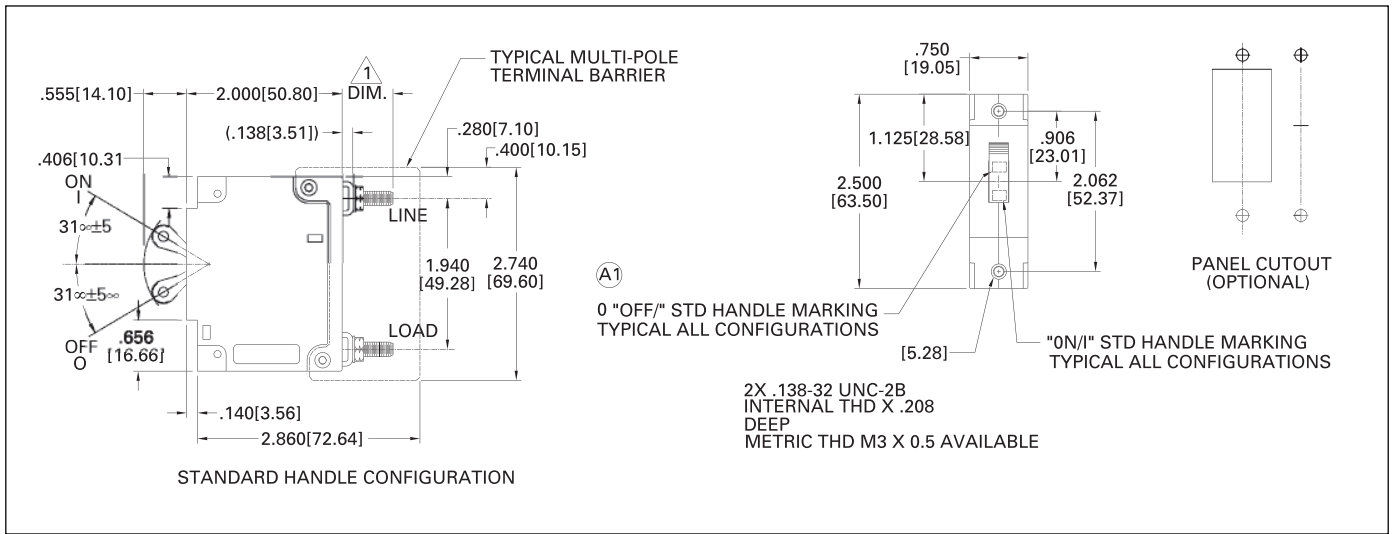

AMR CATALOG NUMBERING SYSTEM

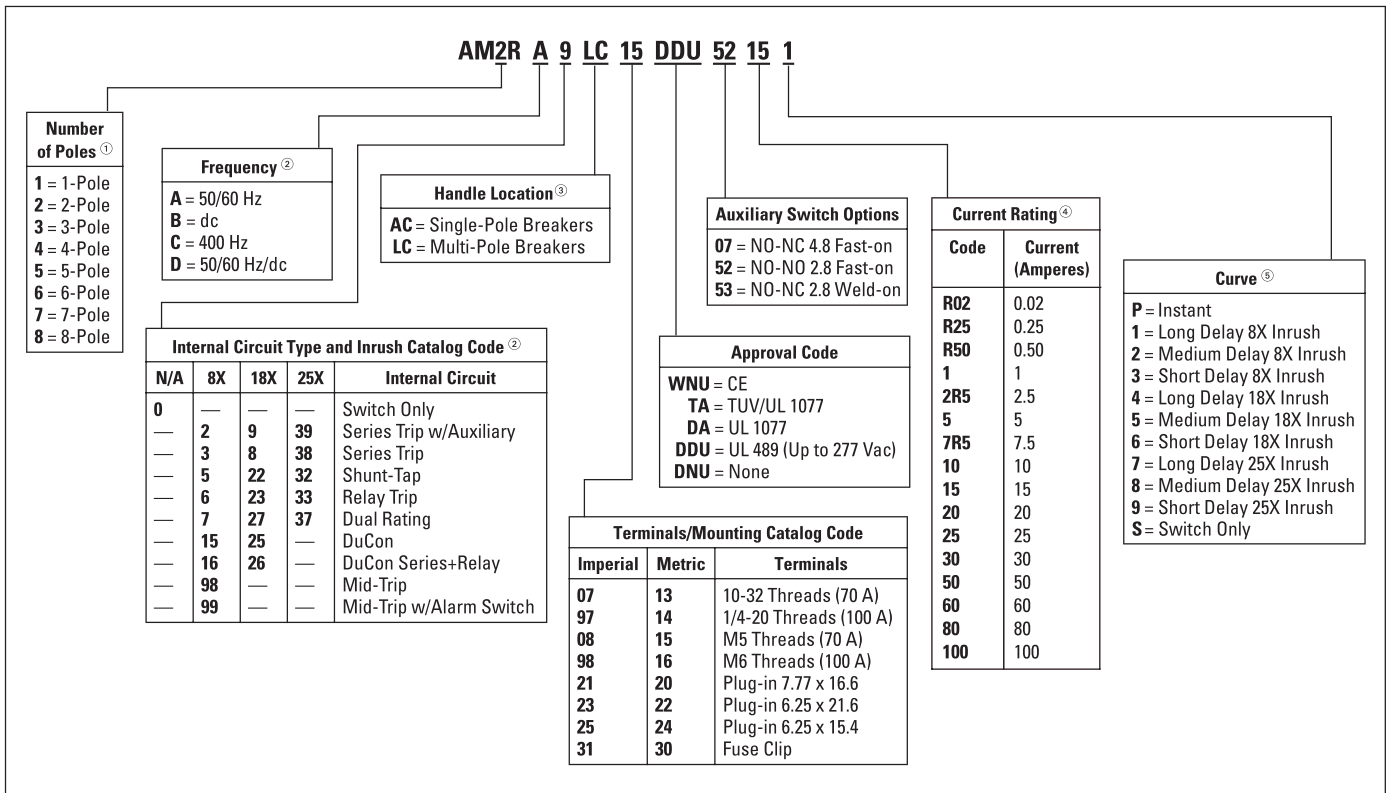

- ① Select from 1 to 8 poles, and enter the number in position 3 of the catalog number. For example, an AM3L would identify a 3-pole AML breaker.
- ② On multi-pole breakers, Steps 2 and 3 can be repeated if subsequent poles are different than the first. Identification starts from left-hand side when viewing the front of the breaker.
- ③ These will provide standard handle locations. For additional options, contact the Technical Resource Center.
- ④ Enter the whole number current rating. For example, use code "15" for a 15 A current rating. For fractional amperages, use an "R" to designate the decimal point. For 0.10 A, enter the code "R10." Current range up to 100 amperes 50/60 Hz, 60 amperes 400 Hz, 100 Adc.
- ⑤ Specific data on trip curves can be found on the Web at www.EatonElectrical.com/heinemann.

TYPICAL DIMENSIONS

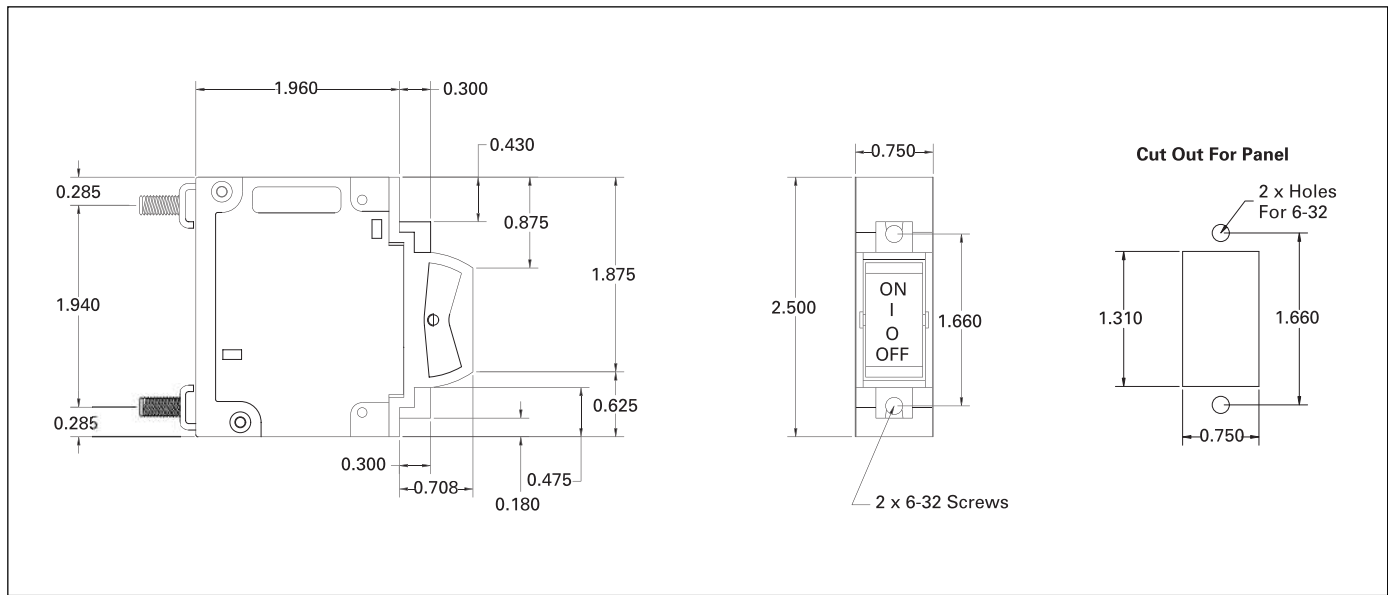

ACR CATALOG NUMBERING SYSTEM

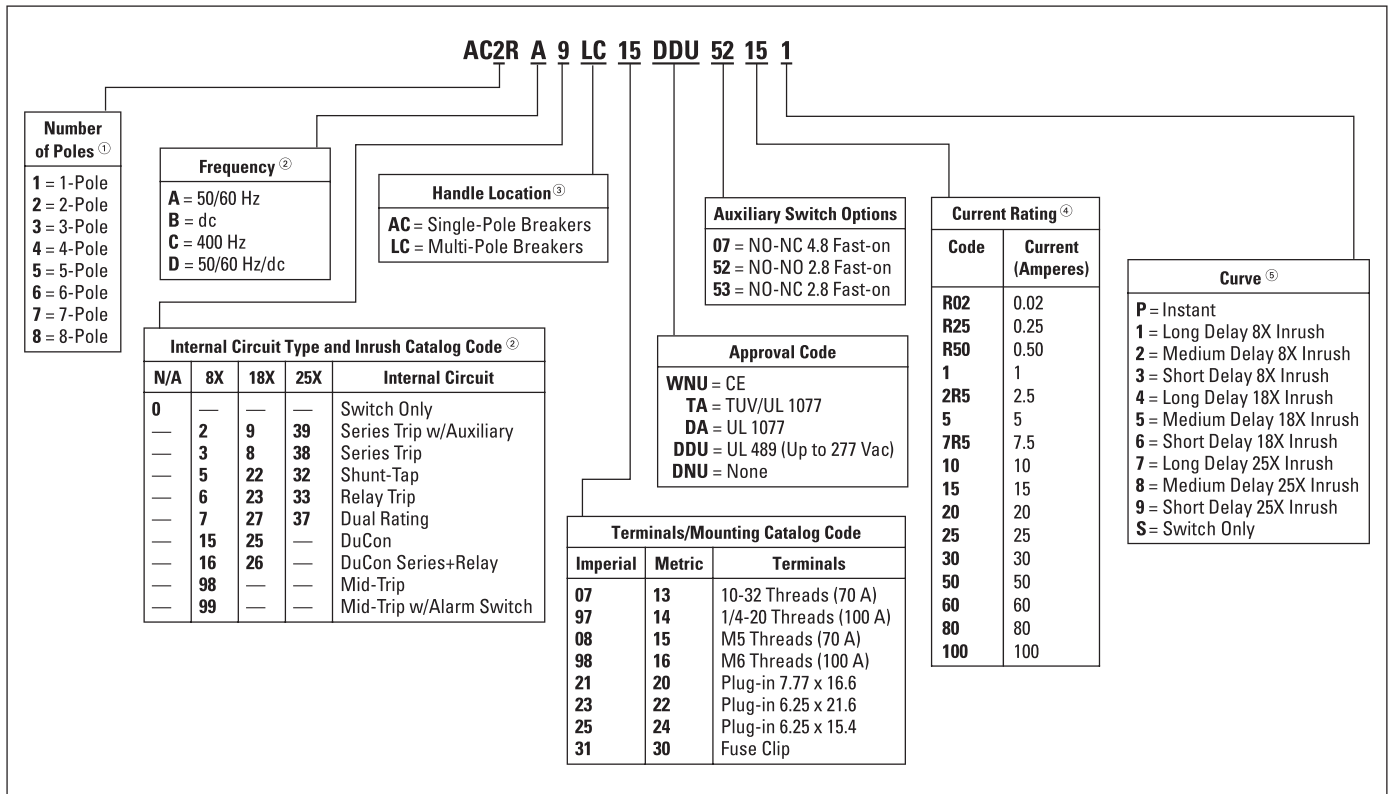

- ① Select from 1 to 8 poles, and enter the number in position 3 of the catalog number. For example, an AM3L would identify a 3-pole AML breaker.
- ② On multi-pole breakers, Steps 2 and 3 can be repeated if subsequent poles are different than the first. Identification starts from left-hand side when viewing the front of the breaker.
- ③ These will provide standard handle locations. For additional options, contact the Technical Resource Center.
- ④ Enter the whole number current rating. For example, use code "15" for a 15 A current rating. For fractional amperages, use an "R" to designate the decimal point. For 0.10 A, enter the code "R10." Current range up to 100 amperes 50/60 Hz, 60 amperes 400 Hz, 100 Adc.
- ⑤ Specific data on trip curves can be found on the Web at www.EatonElectrical.com/heinemann.

TYPICAL DIMENSIONS

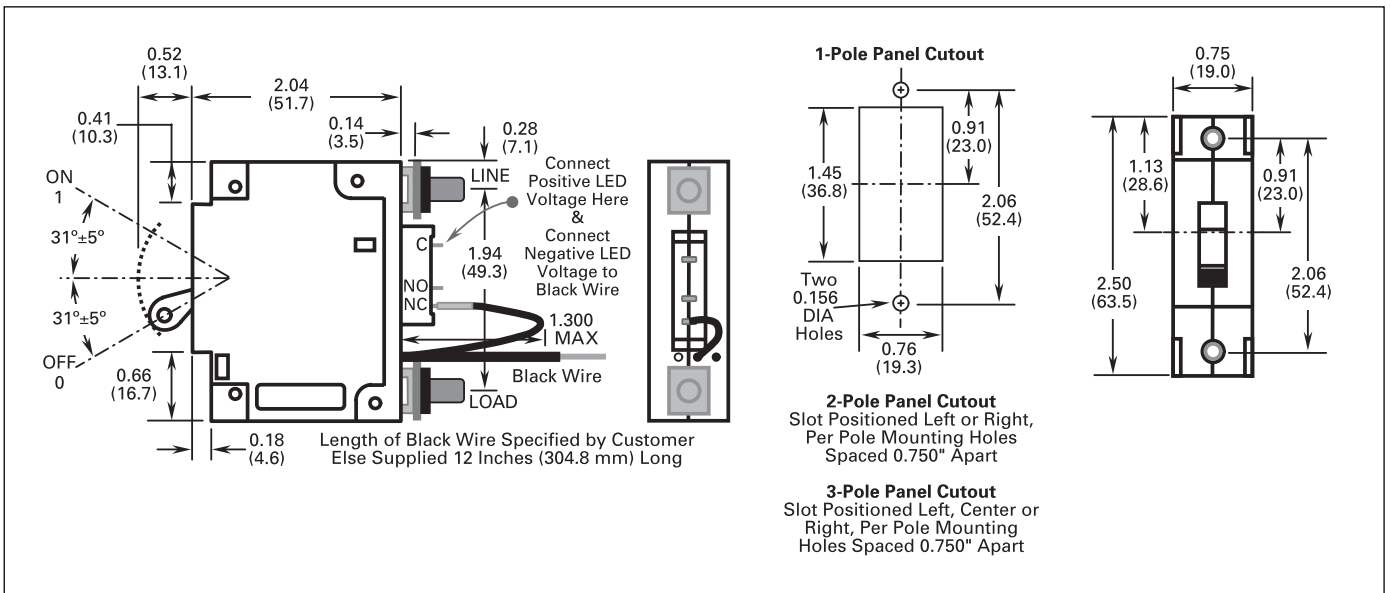

AML CATALOG NUMBERING SYSTEM

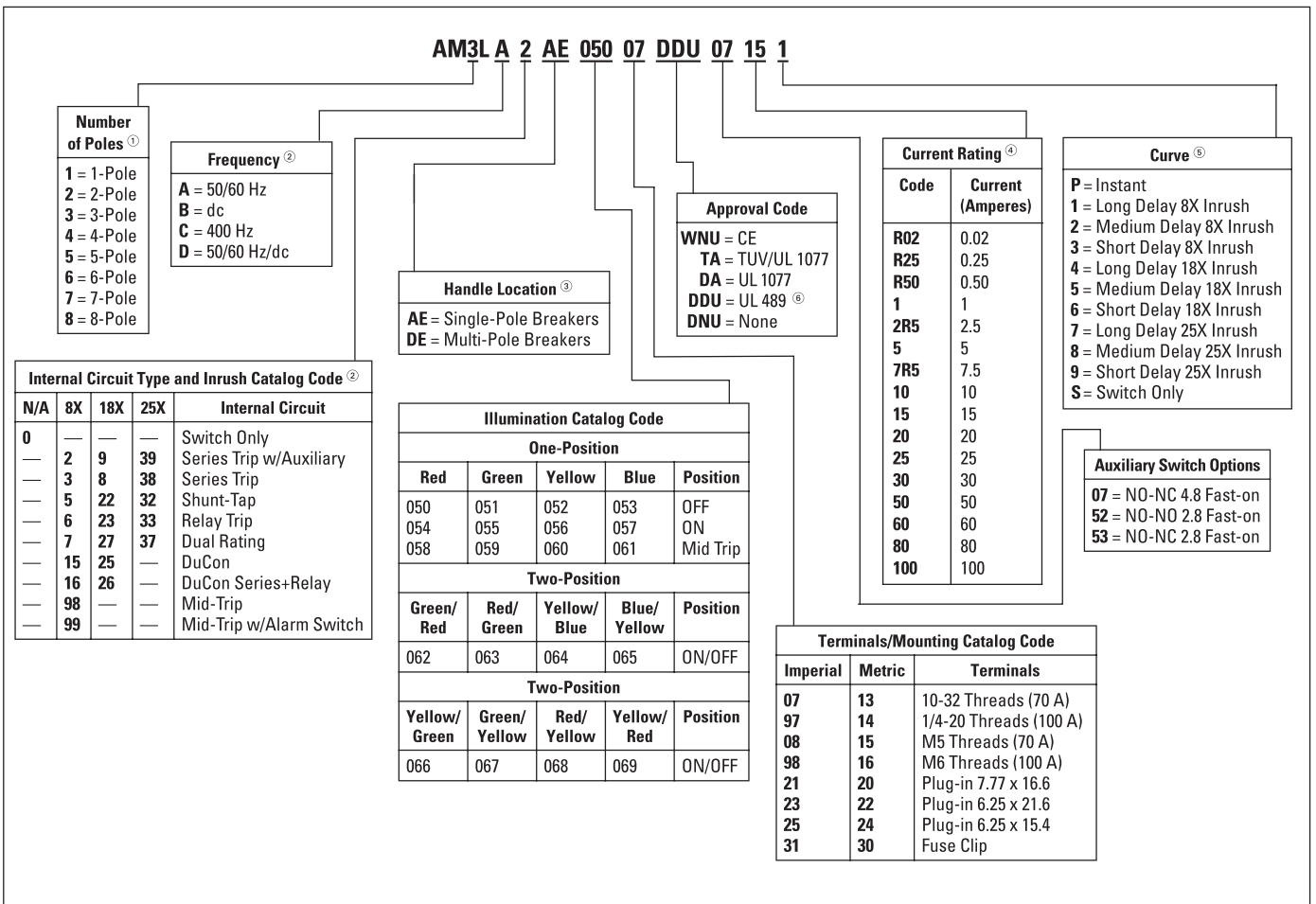

① Select from 1 to 8 poles, and enter the number in position 3 of the catalog number. For example, an AM3L would identify a 3-pole AML breaker.

② On multi-pole breakers, Steps 2 and 3 can be repeated if subsequent poles are different than the first. Identification starts from left-hand side when viewing the front of the breaker.

③ These will provide standard handle locations. For additional options, contact the Technical Resource Center.

④ Enter the whole number current rating. For example, use code "15" for a 15 A current rating. For fractional amperages, use an "R" to designate the decimal point. For 0.10 A, enter the code "R10."

⑤ Specific data on trip curves can be found on the Web at www.EatonElectrical.com/heinemann.

⑥ Up to 277 Vac.

Frame Information

C Series



CD Rear Connection Front Mounting



CF Front Connected Back Panel Mounting

Eaton's Heinemann C Series breakers incorporate the benefits of hydraulic-magnetic technology in a familiar molded case design. The C Series is popular in outdoor locations, in either high temperature or low temperature environments where nuisance tripping might have been a problem in the past.

The C Series is built for a wide range of applications, and is one of the most versatile designs. From heating and air conditioning to modern railcars, the C Series breaker is built for the most demanding industrial applications.

Due to its rugged construction, the C Series is UL listed through 240 Vac or 125 Vdc. The breaker also carries ratings up to 600 Vac as a UL Recognized Device under UL 508.

With the precision overcurrent protection provided by the C Series, many manufacturers have been able to extend their warranties and deliver more reliability to their customers. Popular in the HVAC market, the C Series delivers true equipment protection, ensuring OEMs that their equipment will be safe in any environment.

Available in a wide range of mounting options, the C Series breaker can be ordered as either a front or back connected device.

Features

Environmental, Vibration and Shock Resistant

Mil-spec qualification for fungus resistance, humidity, salt spray resistance and shock vibration resistance.

Heat-Induced Nuisance Tripping Eliminated

The protector is designed to "hold in" at 100% continuous rated current, regardless of ambient temperatures from -40°C +85°C.

Immediate Reset After Trip

The protector can be reset (closed) immediately after an overcurrent trip without a "cooling off" period.

1/2 Cycle High Inrush Tolerance — 8X (standard) and 25x

The protector is available with different levels of tolerance to 1/2 cycle current spikes. Standard tolerance is 8X the continuous current rating; in addition, 25X is also available.

Overcurrent Curves, Long, Medium or Short Delay

Time characteristic curves are available as Short, Medium and Long Delay.

Integral Auxiliary Switch (Optional Selection)

One auxiliary switch (a or b) can be factory installed per pole. A separate pole for auxiliary is NOT required. Contact Eaton for price adder.

Precise Overcurrent Calibration

The protector can be precisely calibrated to a wide variety of current ratings, from 0.1 to 100 continuous amperes.

Standards and Certifications

UL 1077/UL 489 and CSA 22.2.

Standard Catalog Numbers

Standard C Series breakers are UL listed for applications at 240 volts or less, and are built with mechanical lugs for cable connection. All breakers are panel mount, cable in/out design.

Standard Breaker Configurations

The C Series can be ordered in a number of standard configurations utilizing the tables to the right. Once you create your catalog number, you can contact our Technical Resource Center for verification and quotations.

Custom Applications

The C Series is also available in a number of custom configurations to meet your specific application needs. To order a special application breaker, you can visit our Web site at www.EatonElectrical.com/heinemann for a list of custom modifications and information on how to obtain a proprietary catalog number. You may also contact the Technical Resource Center for application information and breaker selection assistance.

Standard Product Offering

CF Standard Breakers are configured for ac circuits, back panel mounting, and cable in/cable out. Standard breakers are configured for ac circuits, rear connection.

POLES	CURRENT	CURVE	CATALOG NUMBER
1	15 A	2	CD1A3U001502A
1	15 A	3	CD1A3U001503A
1	20 A	2	CD1A3U002002A
1	20 A	3	CD1A3U002003A
1	30 A	2	CD1A3U003002A
1	30 A	3	CD1A3U003003A
2	15 A	2	CD2A3U001502A
2	15 A	3	CD2A3U001503A
2	20 A	2	CD2A3U002002A
2	20 A	3	CD2A3U002003A
2	30 A	2	CD2A3U003002A
2	30 A	3	CD2A3U003003A
3	15 A	2	CD3A3U001502A
3	15 A	3	CD3A3U001503A
3	20 A	2	CD3A3U002002A
3	20 A	3	CD3A3U002003A
3	30 A	2	CD3A3U003002A
3	30 A	3	CD3A3U003003A
3	50 A	3	CD3A3U005002A
3	50 A	2	CD3A3U005003A
3	60 A	3	CD3A3U006002A
3	60 A	2	CD3A3U006003A
3	100 A	3	CD3A3U010002A
3	100 A	2	CD3A3U010003A

POLES	CURRENT	CURVE	CATALOG NUMBER
1	15 A	2	CF1G3U001502A
1	15 A	3	CF1G3U001503A
1	20 A	2	CF1G3U002002A
1	20 A	3	CF1G3U002003A
1	30 A	2	CF1G3U003002A
1	30 A	3	CF1G3U003003A
2	15 A	2	CF2G3U001502A
2	15 A	3	CF2G3U001503A
2	20 A	2	CF2G3U002002A
2	20 A	3	CF2G3U002003A
2	30 A	2	CF2G3U003002A
2	30 A	3	CF2G3U003003A
3	15 A	2	CF3G3U001502A
3	15 A	3	CF3G3U001503A
3	20 A	2	CF3G3U002002A
3	20 A	3	CF3G3U002003A
3	30 A	2	CF3G3U003002A
3	30 A	3	CF3G3U003003A
3	50 A	3	CF3G3U005002A
3	50 A	2	CF3G3U005003A
3	60 A	3	CF3G3U006002A
3	60 A	2	CF3G3U006003A
3	100 A	3	CF3G3U010002A
3	100 A	2	CF3G3U010003A

TYPICAL DIMENSIONS

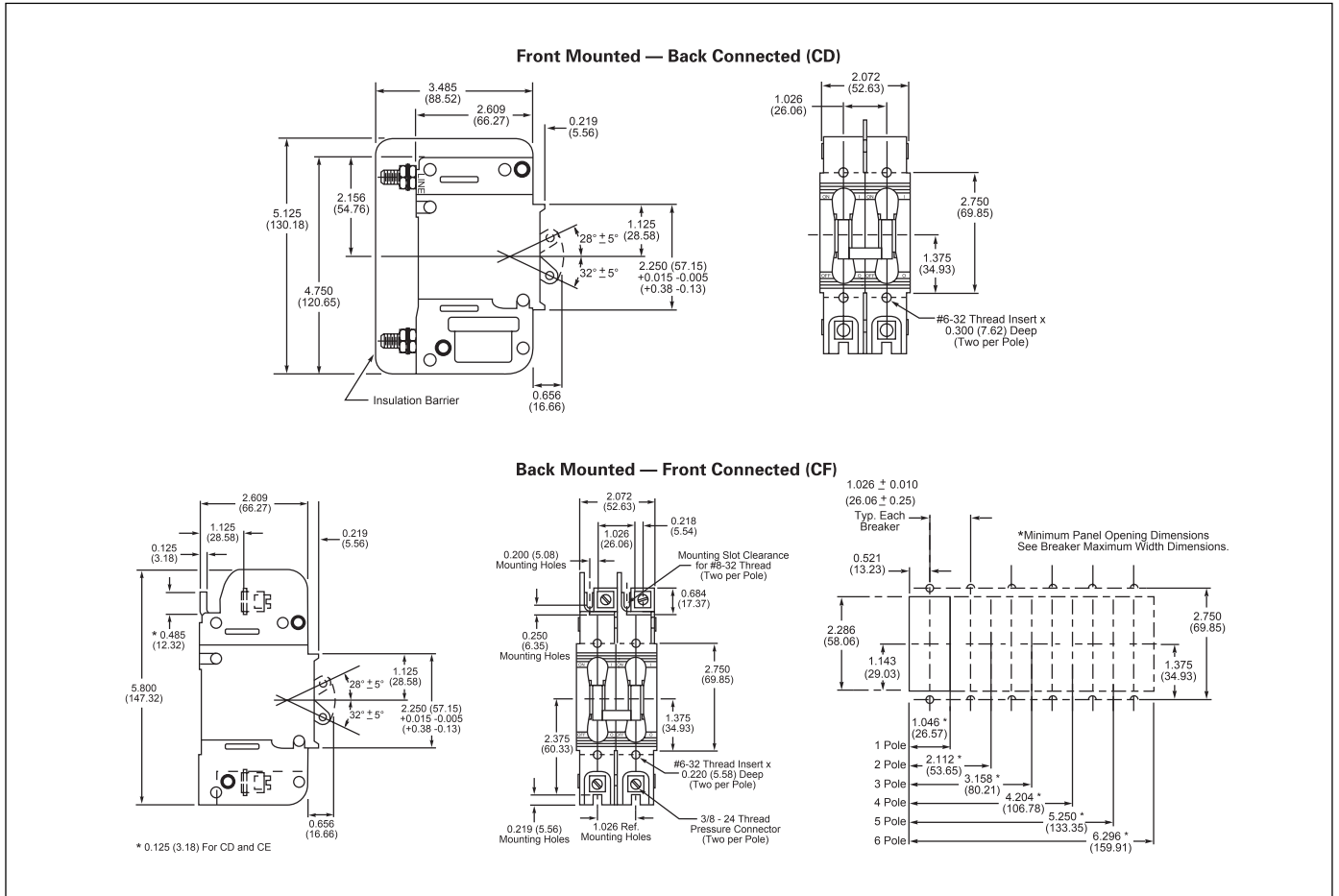

C SERIES CATALOG NUMBERING SYSTEM

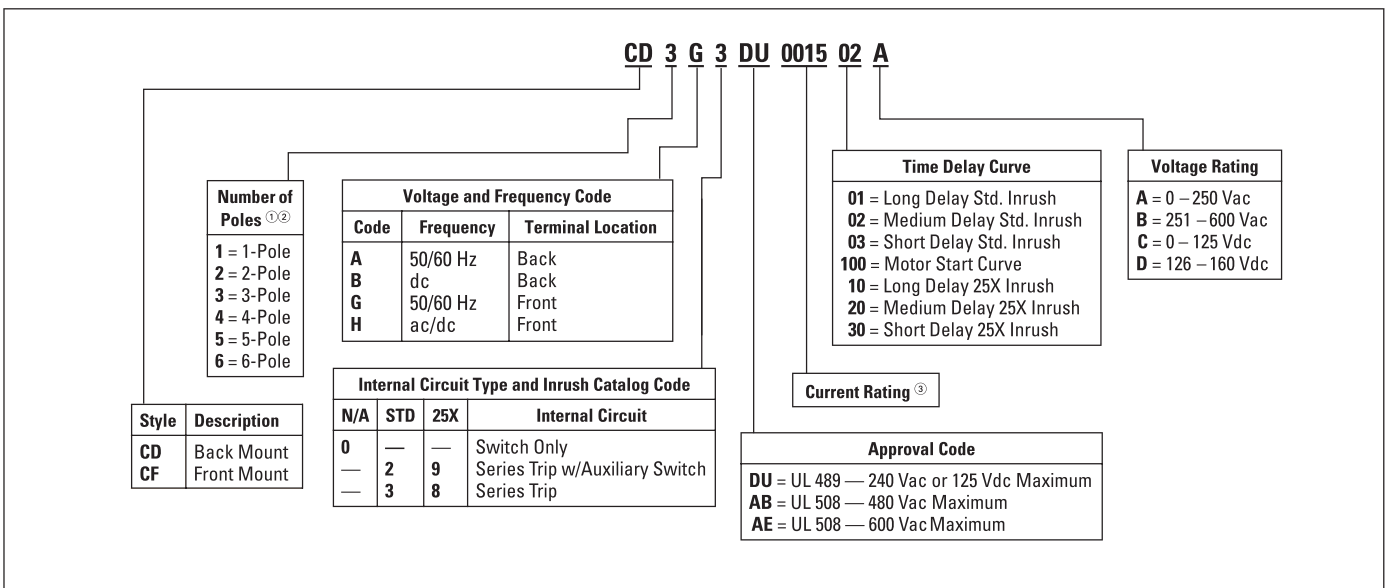

- ① Select from 1 to 6 poles, and enter the number in position 3 of the catalog number. For example, a CD3 would identify a 3-pole C Series breaker.
- ② Style includes Toggle Handle with Black ON/OFF handle color.
- ③ Enter the four digit current rating. For example, use code "0015" for a 15 ampere current rating. For fractional amperages use an "R" to designate the decimal point. For 0.10 ampere, enter the code "0R10." Available from 0.10 – 50 amperes.

Frame Information

GH Series



Eaton's GH Series breaker offers the benefits of hydraulic-magnetic protection in a compact, economical design. Heineemann brand breakers have proven their ability by performing in harsh environment installations, indoor and outdoor, requiring a compact, environmentally stable breaker rated to 100 amperes at 480 Vac.

Because of their ability to furnish both close-rated locked rotor protection and running overcurrent protection without derating in extreme and highly variable ambient conditions, the Series GH breakers are popular in a variety of industries — air conditioning, electric heating, computer main frame and central processing, transportation and many others. In addition, since the GH Series utilizes hydraulic-magnetic technology, you can specify a breaker to match your particular application.

Features

Fungus and Humidity Resistance

Provided in accordance with MIL-STD-202 by treating all ferrous parts with a special moisture-resistant finish and by using special springs and fungus-resistant cases, covers and handles.

Shock

Tested in accordance with MIL-STD-202, Method 213, Test Condition I (100G's at 6 milliseconds).

Vibration

Tested in accordance with MIL-STD-202, Method 204, 10 to 500 Hz, 0.06-inch total excursion on three mutually perpendicular planes. Shock and vibration tests apply to time delay breakers only and are performed with units carrying full rated current.

Life

10,000 cycles.

Approximate Weights GH3
3.3 lbs. (14.96 kg)

Dielectric Strength

1960 Vac.

Insulation Resistance (Internal Resistance):

See impedance chart. Impedance or internal resistance across breaker at full rated load.

Standard Breaker Configurations

The GH Series can be ordered in a number of standard configurations utilizing the table to the right. Once you create your catalog number, you can contact our Technical Resource Center for verification and quotations.

Custom Applications

The GH Series is also available in a number of custom configurations to meet your specific application needs. To order a special application breaker, you can visit our Web site at www.EatonElectrical.com/heineemann for a list of custom modifications and information on how to obtain a proprietary catalog number. You may also contact the Technical Resource Center for application information and breaker selection assistance.

Standard Product Offering

POLES	CURRENT	CURVE	CATALOG NUMBER
3	15 A	2	GH3A3U001502B
3	15 A	3	GH3A3U001503B
3	20 A	2	GH3A3U002002B
3	20 A	3	GH3A3U002003B
3	30 A	2	GH3A3U003002B
3	30 A	3	GH3A3U003003B
3	50 A	3	GH3A3U005002B
3	50 A	2	GH3A3U005003B
3	60 A	3	GH3A3U006002B
3	60 A	2	GH3A3U006003B
3	100 A	3	GH3A3U010002B
3	100 A	2	GH3A3U010003B

BASIC DIMENSIONS

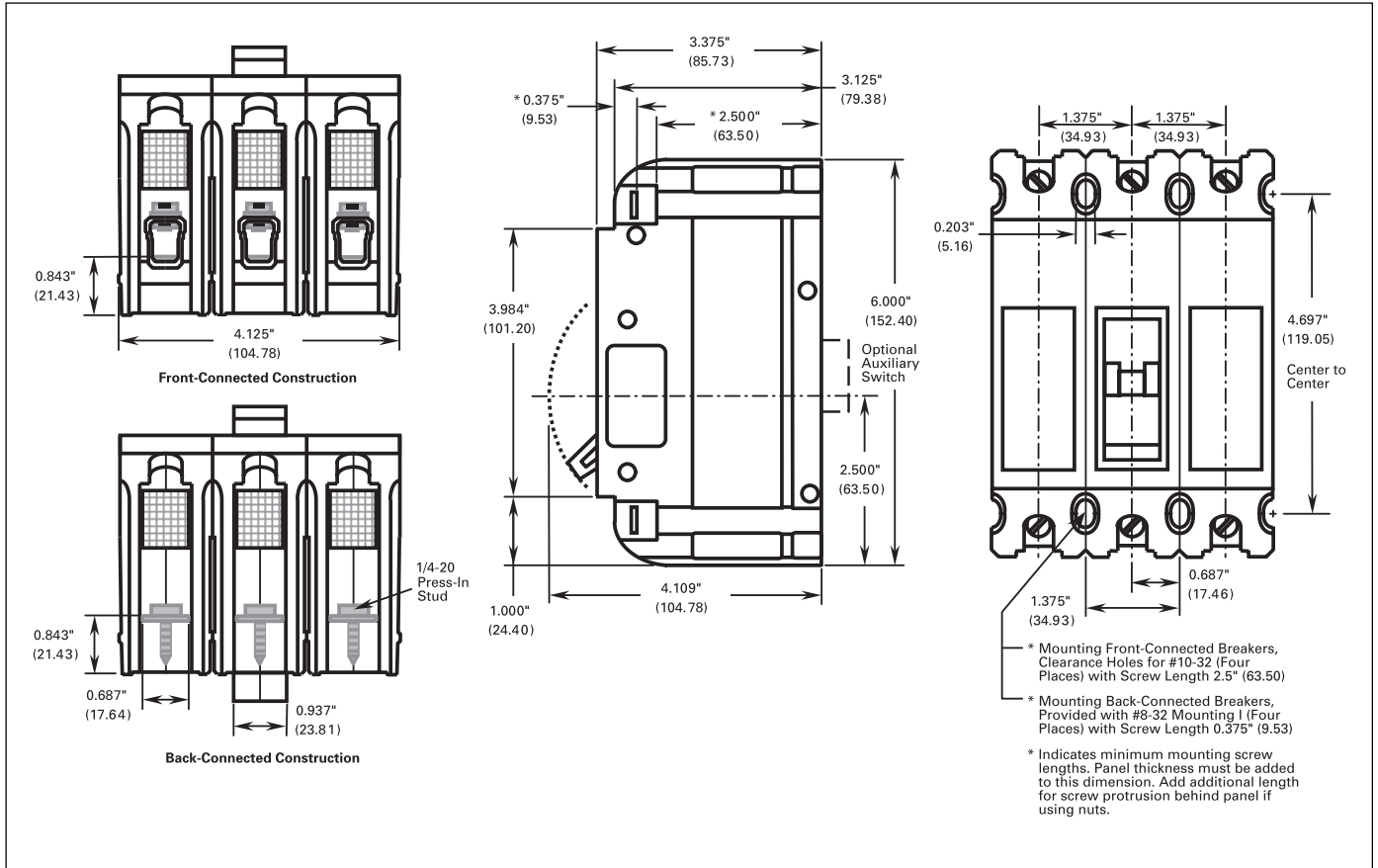

GH CATALOG NUMBERING SYSTEM

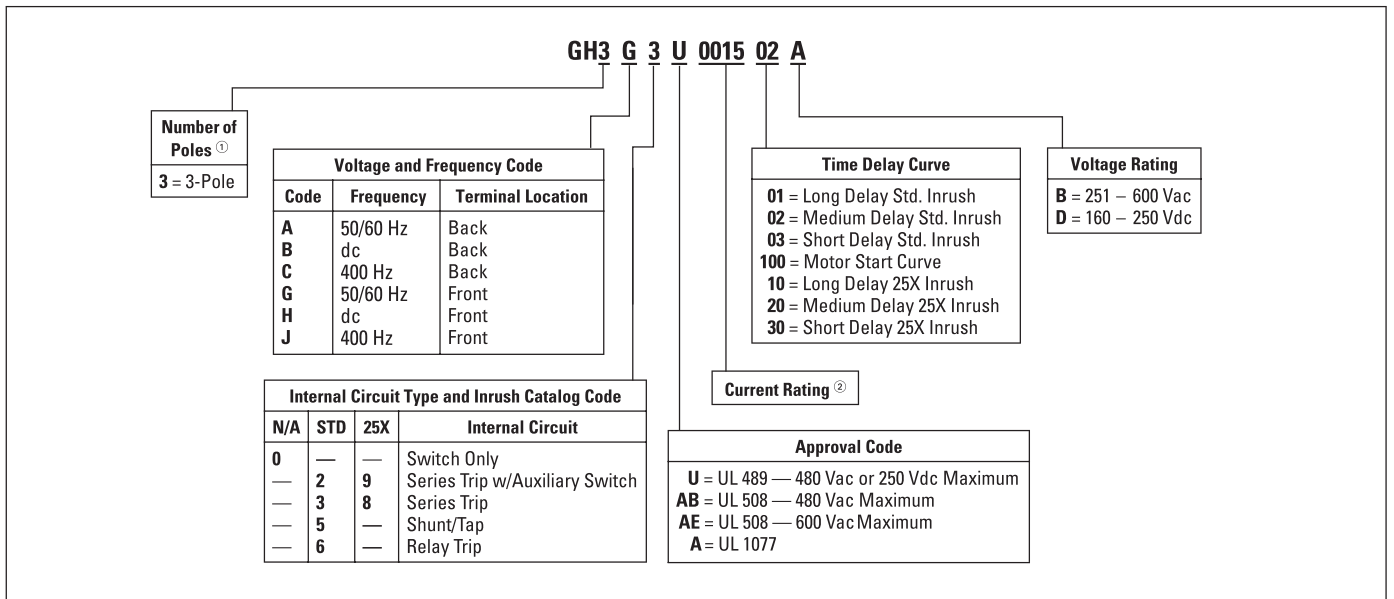

① Style includes Toggle Handle with Black ON/OFF handle color.

② Enter the four digit current rating. For example, use code "0015" for a 15 ampere current rating. GH Series breakers are available from 15 – 100 amperes.

Frame Information

AM1P Series



Increased performance and compact packaging make the AM1P perfect for demanding dc applications. The AM1P delivers maximum performance in the smallest package size available in the industry.

With a 250 ampere current rating and 50,000 ampere interrupting capacity at 80 Vdc, the AM1P is ideal for telecommunications sites with space constraints or high current applications.

Using a parallel wiring configuration, the AM1P delivers 200 amperes in a 2-pole design and 250 amperes in a 3-pole design. In addition, the AM1P employs a proprietary technology known as PCE or Precision Current Equalization. This technology ensures that current flows evenly through all poles and nuisance tripping is eliminated.

The AM1P Series is UL 489A listed.

Features

- Maximum current rating up to 250 amperes.
- Plug-in, screw and stud terminals.
- Operating temperature -40°C to +85°C.
- Shock-tested for shock in accordance with MIL-STD-202, Method 213, Test Condition I.
- Vibration-tested in accordance with MIL-STD-202, Method 204, while carrying full-rated current.
- Minimum life of 10,000 on/off operations, with 6,000 at rated current and voltage, and 4,000 at no load.
- Dielectric strength tested in accordance with MIL-STD-202, Method 1500 volts at 50/60 Hz, 1100 Vdc (or twice rating plus 1000 volts).
- Insulation resistance of 100 Megaohms minimum at 500 Vdc, per MIL-STD-202, Method 302.
- Flammability specifications of UL 94-VO Case, UL 94-HB Handle.

AM1P CATALOG NUMBERING SYSTEM

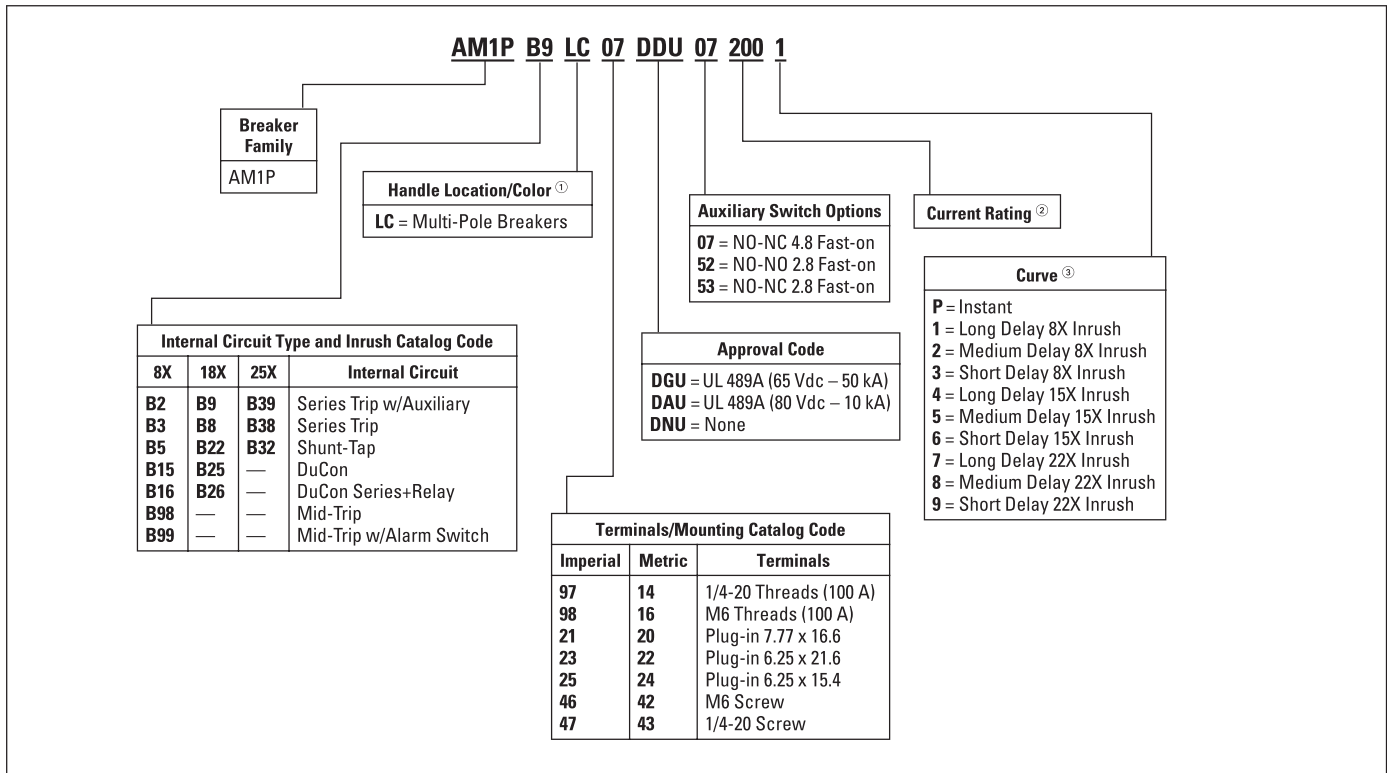

① Specify LC for multi-pole breakers with common trip handle as standard.

② Enter the three digit current rating from 101 – 250 amperes. 101 – 200 amperes is configured as 2-poles in parallel, 201 – 250 as 3-poles in parallel.

③ Specific data on trip curves can be found on the Web at www.EatonElectrical.com/heinemann.

TYPICAL DIMENSIONS

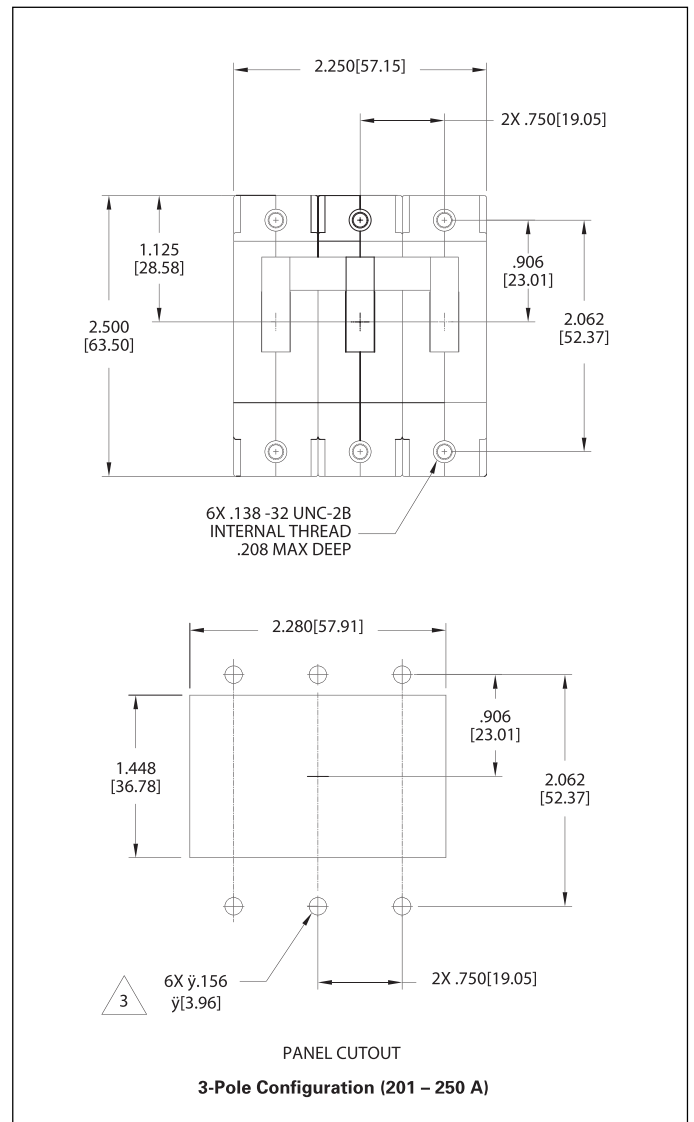
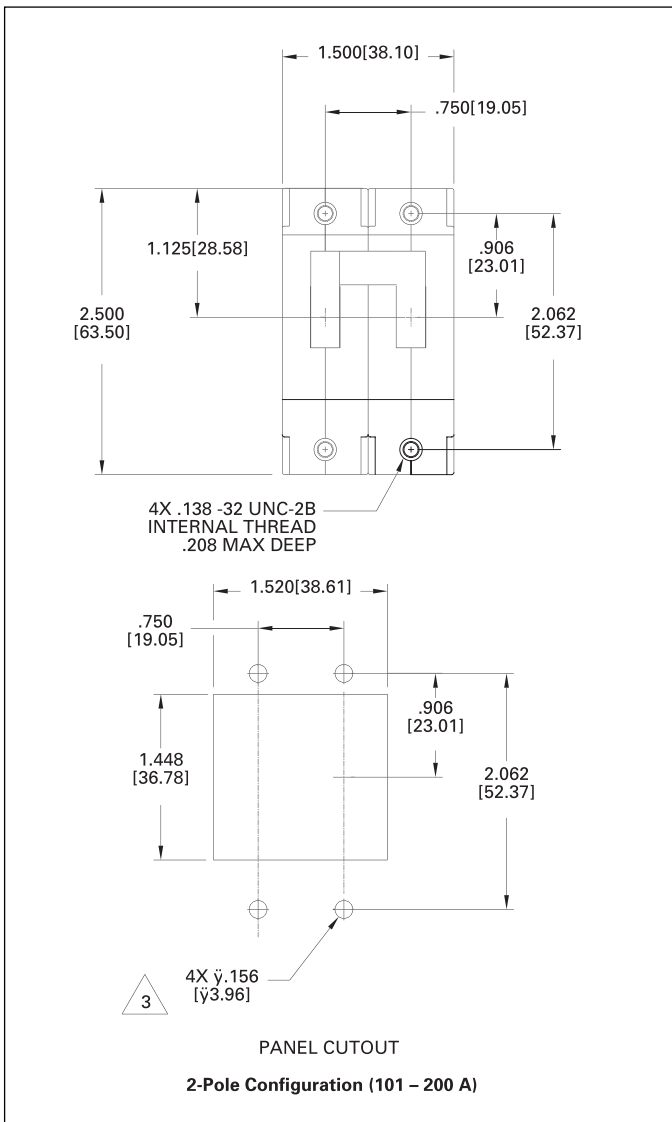
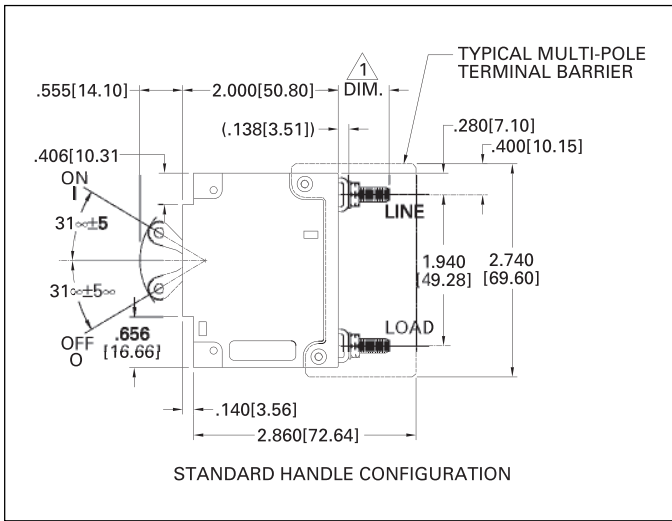

Frame Information

GJ Series

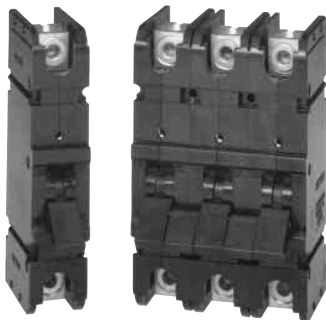

Heinemann Series GJ Circuit Breakers are the logical choice for high-current service entrance and panelboard installations, as well as control and protection of commercial and industrial lighting, transformers, motors and power supplies. The precisely tailored time delays and ability to interrupt high currents make them ideal for critical applications with inductive or other loads of up to 280 amperes.

The hydraulic-magnetic load-sensing and time delay mechanism of the Series GJ is insensitive to changes in ambient or enclosure temperature, adapting it to service conditions encountered in electric vehicles, roof-mounted air conditioners and other outdoor or "heat-loaded" equipment. Unlike thermal breakers, the GJ breaker can be loaded to rated capacity without causing nuisance tripping when ambient temperature rises. It is also well suited for protecting line-sensitive loads, such as critical data processing equipment and computers.

Options

- 1-, 2- or 3-pole models.
- Fast, medium or slow response times to accurately match load conditions.
- Auxiliary switch for signaling.
- Back connected series trip, relay or shunt configurations.
- A mounting kit assembly is available for the GJ breakers (Cat. No. 009-18155).

Features

Standard Maximum Voltages:

- GJ1, GJ2 and GJ3: 240 Vac, 50/60/400 Hz.
- GJ1: 125 Vdc.
- GJ2: 125/250 Vdc.

Breakers will be labeled with standard maximum (UL) voltage unless otherwise specified.

Maximum Current Rating:

Up to 280 amperes per pole.

Interrupting Capacities

- GJ1: 10 kA at 240 Vac
160 Vdc, 25 kA at 65 Vdc.
- GJ2/3: 18 kA at 240 Vac
10 kA at 125/250 Vdc.

Terminal Types

Standard: front-connected, pressure-wire terminals accepting copper or aluminum wire sizes from 78 to 37 mm² (6 to 300 kcmil). Back-connected and many special terminals are available. Consult Customer Service Center.

Operating Temperature Range:

-40°C to +85°C.

Fungus and Humidity Resistance

MIL-STD-202. Ferrous parts incorporate special moisture-resistant finish. Springs, cases and handles are made from fungus-resistant materials.

Shock

MIL-STD-202, Method 213.

Test Condition

100g's for 6 milliseconds (Time delay breakers only).

Vibration

MIL-STD-202, Method 24, 10 to 500 Hz, 0.06-inch total excursion on three mutually perpendicular planes (time delay breakers only). Testing completed at full rated current 50/60 Hz.

Standard Breaker Configurations

The GJ Series can be ordered in a number of standard configurations utilizing the GJ Catalog Numbering System. Once you create your catalog number, you can contact our Technical Resource Center for verification and quotations.

Custom Applications

The GJ Series is also available in a number of custom configurations to meet your specific application needs. To order a special application breaker, you can visit our Web site at www.EatonElectrical.com/heinemann for a list of custom modifications and information on how to obtain a proprietary catalog number. You may also contact the Technical Resource Center for application information and breaker selection assistance.

BASIC DIMENSIONS

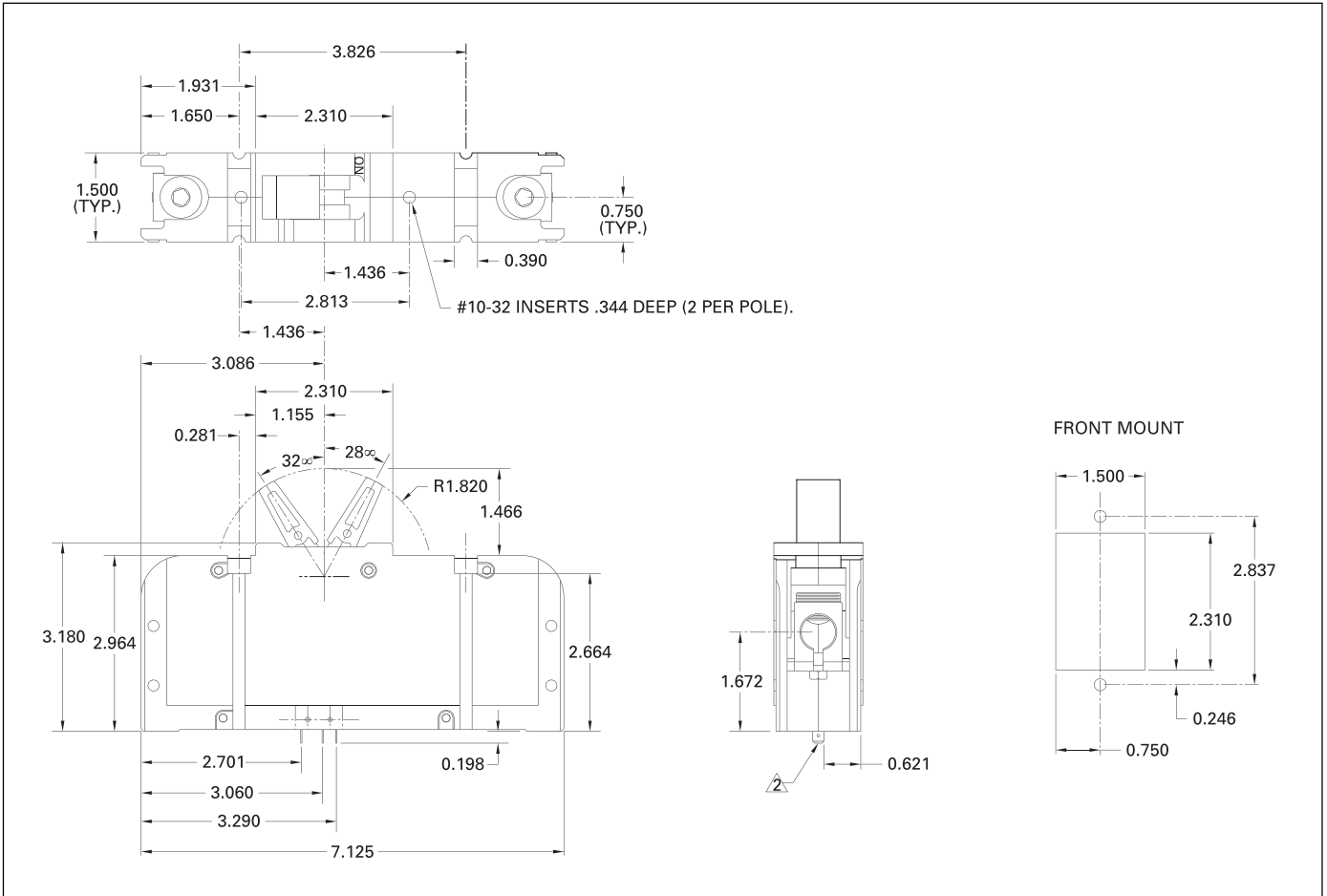

GJ CATALOG NUMBERING SYSTEM

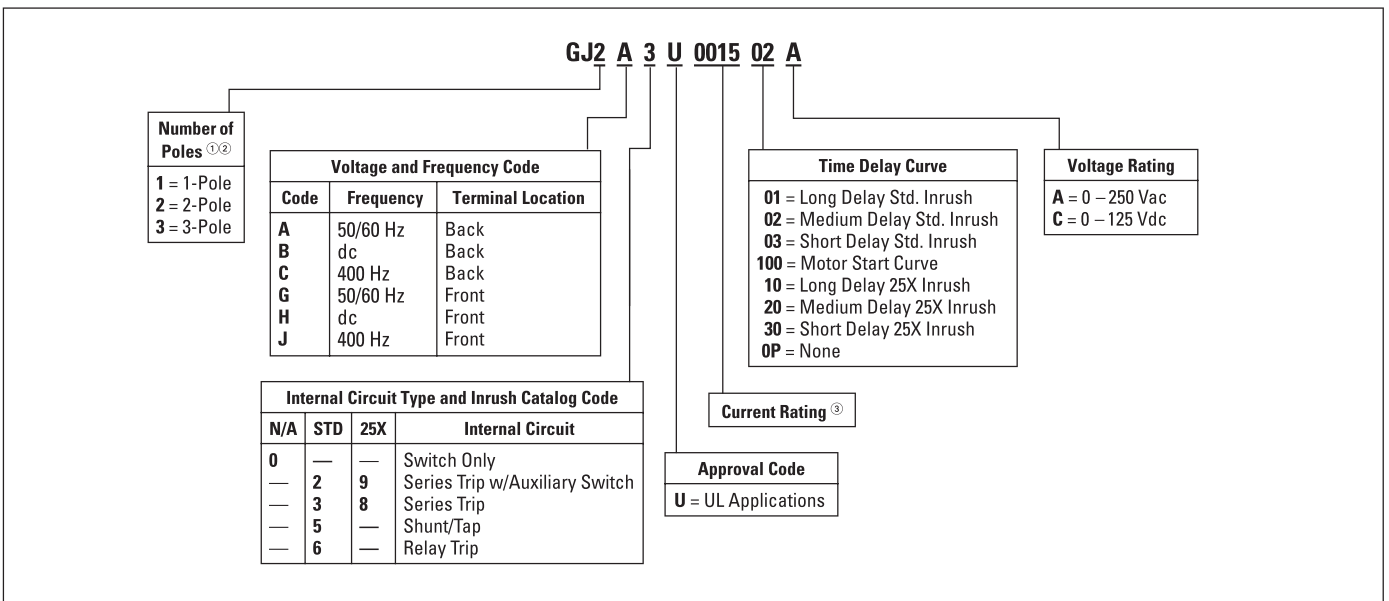

① Select from 1 to 3 poles, and enter the number in position 3 of the catalog number. For example, a GJ2 would identify a 2-pole GJ Series breaker.
 ② Style includes Toggle Handle with Black ON/OFF handle color.
 ③ Enter the four digit current rating. For example, use code "0015" for a 15 ampere current rating. Breakers are available from 100 – 280 amperes.

Frame Information

GJ1P Series



Eaton Corporation's Heinemann GJ1P breakers offer high-quality circuit protection for dc applications from 100 to 1200 amperes.

Their precisely tailored time delays and ability to interrupt high currents makes them ideally suited for critical applications. On overloads exceeding 1000 – 1400% of rating, there is no intentional time delay and the breaker interrupts currents of as much as 100,000 amperes at 65 Vdc up to 1200 amperes.

An optional shunt (25 or 50 millivolt full scale) permits metering of current. Since the shunt output is low voltage, light-gauge wiring can be used from shunt to meter. Indication may be displayed in percent, watts, safe/danger or other dial calibrations. In addition, the bus bar is available in two versions, Standard Size and Reduced Size. Contact your Eaton sales representative for more information.

Precision Current Equalization (PCE) Circuit Breakers

GJ1P breakers rated 250 to 1200 amperes are built in parallel construction. Conventional parallel pole breakers can experience uneven current distribution because of variations in internal resistances. This condition can result in nuisance tripping since the higher current in one parallel branch has the same effect as an overload on the sensing element in that branch. Proprietary Precision Current Equalization (PCE) circuit breakers, on the other hand, allow for differences in internal resistances by automatically distributing the current equally through the parallel current sensing elements, minimizing the danger of nuisance tripping.

The UL listed series GJ1P (UL 489) models are available in a choice of fast, medium or slow response times to accurately match load conditions.

They can be ordered in "series trip," "mid-trip" and "switch only" constructions and are available front- or back-mounted, front- or back-connected, with optional auxiliary switches for signaling.

BASIC DIMENSIONS

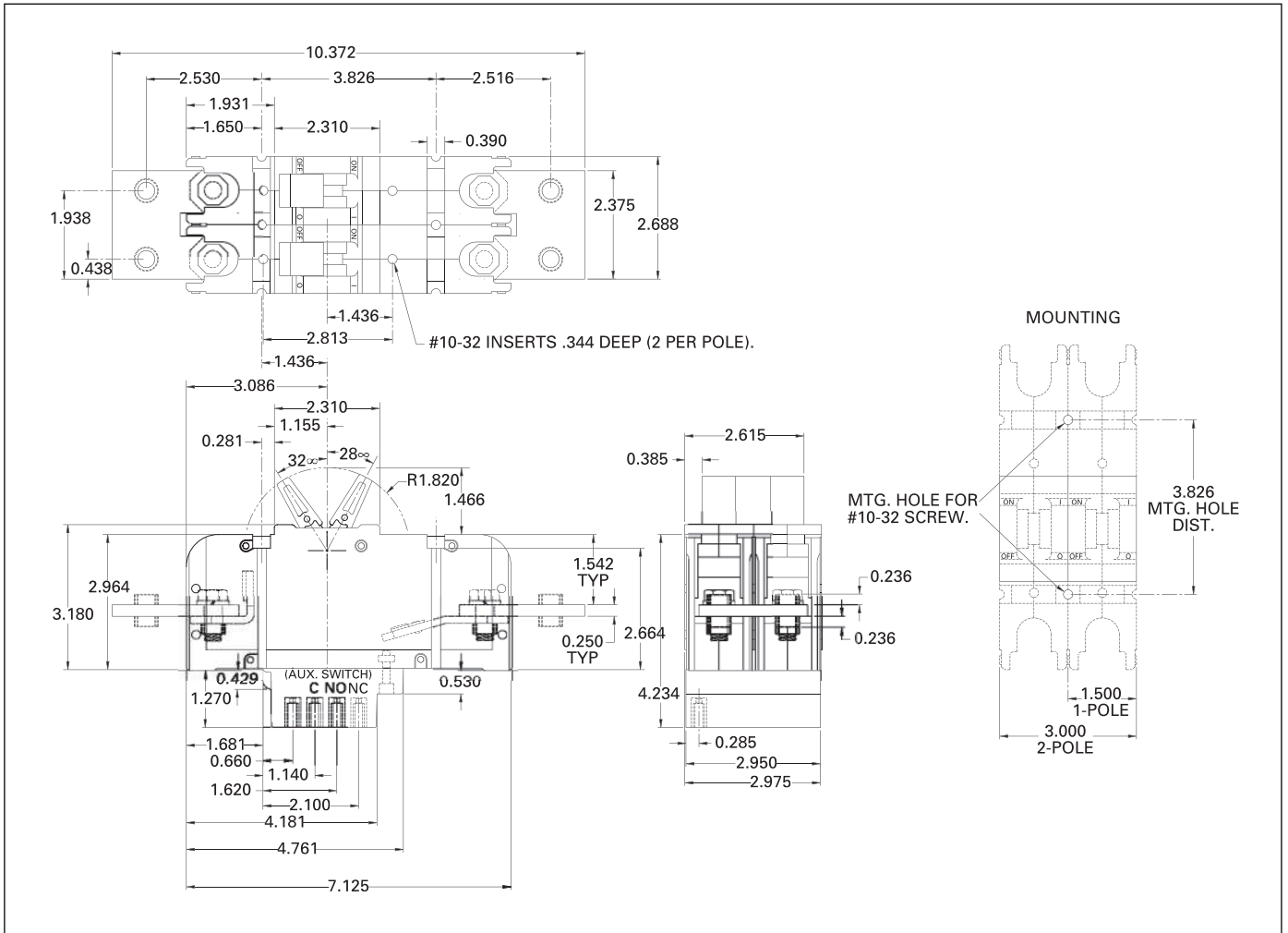

GJ1P CATALOG NUMBERING SYSTEM

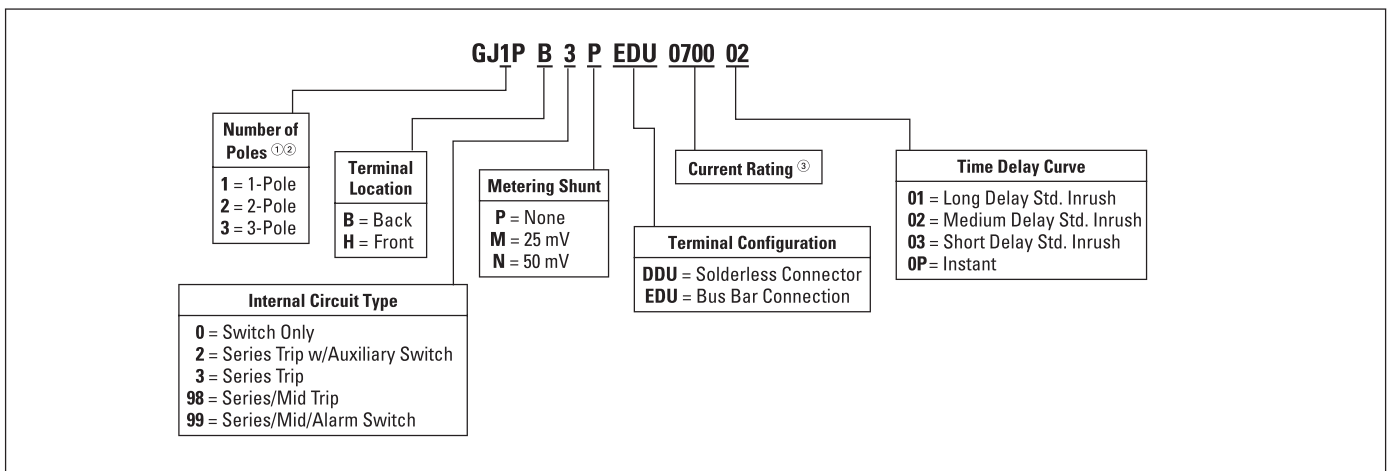

① Select from 1 to 3 poles, and enter the number in position 3 of the catalog number. For example, a GJ1P would identify a 1-pole GJ Series breaker.
 ② Style includes Toggle Handle with Black ON/OFF handle color and 6-32 mounting.
 ③ Enter the four digit current rating. For example, use code "0015" for a 15 ampere current rating. Breakers are available from 100 – 280 amperes.

Special Applications

Industrial Solutions



Marine Industry

Where there is a need for small, lightweight, low-cost reliable circuit breakers, boat designers have found Eaton Heinemann an excellent choice. Long a standard in the industry, Heinemann breakers meet a wide variety of demanding needs in marine craft.

From a single-pole breaker for ON/OFF switching and overcurrent protection on smaller boats to multi-pole breakers with auxiliary functions on larger vessels, you can expect to find a Heinemann breaker that will meet your requirements.

The JA/S, JE/S and AMR circuit breakers are perfect for basic marine applications exposed to temperature variations and vibration. The JE/S adds a watertight seal and is suitable for locations where water spray and splash might occur.

Eaton Heinemann's marine circuit breakers (MAS, MES and MMR) are UL listed under UL 1500 for Marine Applications and meet all U.S. Coast Guard requirements. The marine line is ignition protected and designed for use aboard gasoline-powered craft in engine compartments and closed areas where gasoline vapors may be present.

In addition, Eaton Heinemann offers services and options for OEMs focused on finding ways to reduce costs without sacrificing quality. Eaton can provide fully wired custom panel solutions eliminating the need to deal with multiple vendors and additional procurement costs.

Telecommunications

Eaton Heinemann circuit breakers power nearly half of all wireless telecommunications equipment in the world. Chosen for their precision protection and high reliability in outdoor environments, Eaton Heinemann circuit breakers deliver reliable power eliminating costs for some of the largest wireless carriers in the U.S. and abroad.

If you are an OEM building Radio Base Station Equipment, or looking for ways to distribute dc power more efficiently, Eaton has a solution ready for your application.

Our facilities in Switzerland have designed both integrated distribution modules (IDM) and bus bar solutions to distribute power to your equipment, requiring less labor during fabrication. In addition, we have developed several custom products to improve the reliability of communications equipment in both civilian and military applications.

Eaton Heinemann is also one of the manufacturers of electrical equipment that can combine the benefits of hydraulic-magnetic protection and ac site power protection in conjunction with Eaton Cutler-Hammer Products.

At Eaton Heinemann, we know the telecommunications business, and we can help shorten your product delivery cycle. From design services, to logistics, to contract manufacturing, Eaton can help you keep your customers communicating.





Mobile Equipment

Most mobile equipment used in the construction industry is subjected to harsh temperatures and vibration. Eaton Heinemann breakers maintain calibration from -40°C to +80°C and provide reliable protection in harsh environments. In addition, protective boots are available to eliminate contamination and protect breakers from the weather.



Specialty Lighting

Eaton Heinemann's new AML Lighted Handle Breaker is perfect for a variety of applications including specialty lighting. With UL 489 listings for 120 and 277 volt lighting circuits, the AML gives customers reliable power and indication of breaker status at a glance.



Rail

Vibration and temperature extremes make it extremely difficult to protect circuits in the rail industry. Eaton Heinemann's proven design has been tested to 100G and meets MIL standards for shock and vibration. This makes it perfect for rail applications. Eaton Heinemann offers breakers for power and control circuits onboard today's modern railcars and commands a leading position in the industry.



Critical Power

Eaton Heinemann offers the latest in power protection for today's sophisticated UPS systems. With features like expanded dc ratings and integral control circuits, the Heinemann family of breakers is the choice of the leading UPS OEMs worldwide, including Eaton's own Powerware®.



Eaton's electrical business is a global leader in electrical control, power distribution, and industrial automation products and services. Through advanced product development, world-class manufacturing methods, and global engineering services and support, Eaton's electrical business provides customer-driven solutions under brand names such as Cutler-Hammer®, Powerware®, Durant®, Heinemann®, Holec® and MEM®, which globally serve the changing needs of the industrial, utility, light commercial, residential, and OEM markets. For more information, visit www.EatonElectrical.com.

Eaton Corporation is a diversified industrial manufacturer with 2004 sales of \$9.8 billion. Eaton is a global leader in electrical systems and components for power quality, distribution and control; fluid power systems and services for industrial, mobile and aircraft equipment; intelligent truck drivetrain systems for safety and fuel economy; and automotive engine air management systems, powertrain solutions and specialty controls for performance, fuel economy and safety. Eaton has 56,000 employees and sells products to customers in more than 125 countries. For more information, visit www.eaton.com.

Eaton Electrical Inc.
1000 Cherrington Parkway
Moon Township, PA 15108
United States
tel: 1-800-525-2000
www.EatonElectrical.com

CSA is a registered trademark of the Canadian Standards Association. Cutler-Hammer is a federally registered trademark of Eaton Corporation. Heinemann is a federally registered trademark of Eaton Corporation. Powerware is a registered trademark of Eaton Corporation. UL is a federally registered trademark of Underwriters Laboratories Inc.

EATON

© 2005 Eaton Corporation
All Rights Reserved
Printed in USA
Publication No. PG01100001E / Z3658
September 2005