

REV.
B

SAE AS85049/90

FEDERAL SUPPLY CLASS
5970

RATIONALE

THIS REVISION IS REQUIRED TO INCORPORATE THE OUTSTANDING AMENDMENT, REVIEW FOR KNOWN TECHNICAL ISSUES AND UPDATE TO MEET SAE FORMAT GUIDELINES.

THE REQUIREMENTS FOR PROCURING THE PRODUCT DESCRIBED HEREIN SHALL CONSIST OF THIS SPECIFICATION SHEET AND THE LATEST ISSUE OF SAE AS85049.

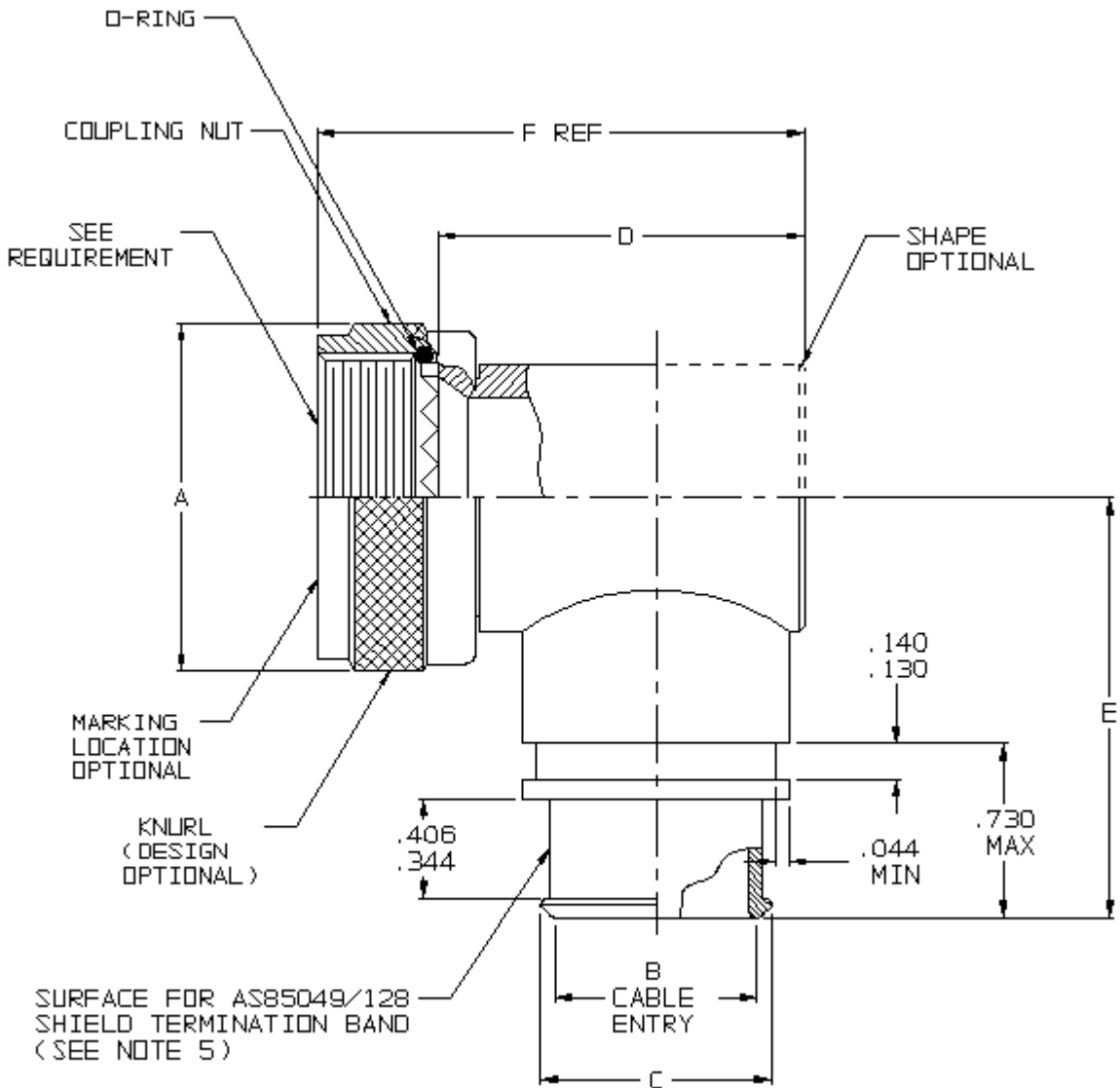
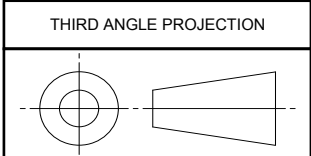

FIGURE 1 - CONFIGURATION AND DIMENSIONS

SAE values your input. To provide feedback on this Technical Report, please visit <http://www.sae.org/technical/standards/AS85049/90B>



SAE Technical Standards Board Rules provide that: "This report is published by SAE to advance the state of technical and engineering sciences. The use of this report is entirely voluntary, and its applicability and suitability for any particular use, including any patent infringement arising therefrom, is the sole responsibility of the user." SAE reviews each technical report at least every five years at which time it may be reaffirmed, revised, or cancelled. SAE invites your written comments and suggestions.

CUSTODIAN: AE-8/AE-8C1

PROCUREMENT SPECIFICATION: AS85049

SAE Aerospace
An SAE International Group

AEROSPACE STANDARD

(R) CONNECTOR ACCESSORIES, ELECTRICAL, BACKSHELL, 90°, SELF-LOCKING, SHIELD BAND TERMINATION, (RFI/EMI), SHRINK SLEEVE ACCOMMODATION, CATEGORY 3B (FOR MIL-DTL-38999 SERIES III AND IV CONNECTORS)

SAE AS85049/90
SHEET 1 OF 4

REV. B

Copyright 2011 SAE International

All rights reserved. No part of this publication may be reproduced, stored in a retrieval system or transmitted, in any form or by any means, electronic, mechanical, photocopying, recording, or otherwise, without the prior written permission of SAE.

TO PLACE A DOCUMENT ORDER: Tel: 877-606-7323 (inside USA and Canada)
Fax: 724-776-0790

Tel: +1 724-776-4970 (outside USA)
Email: CustomerService@sae.org

SAE WEB ADDRESS: <http://www.sae.org>

ISSUED 2000-06 REVISED 2011-04

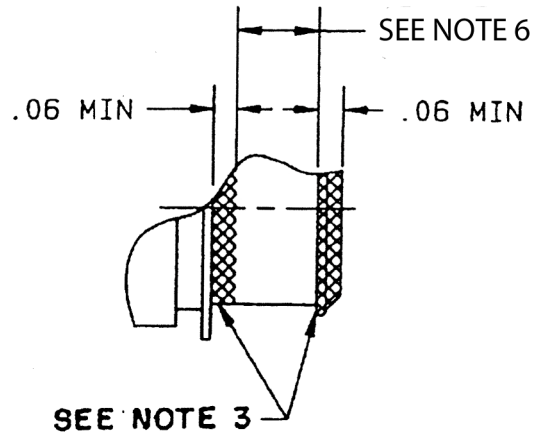

FIGURE 2 - SELECTIVE PLATING

| INCH | MM | INCH | MM | INCH | MM | INCH | MM |
|------|-------|------|-------|-------|-------|-------|-------|
| .044 | 1.12 | .562 | 14.27 | .829 | 21.06 | 1.157 | 29.39 |
| .130 | 3.30 | .583 | 14.81 | .858 | 21.79 | 1.279 | 32.49 |
| .140 | 3.56 | .625 | 15.88 | .895 | 22.73 | 1.350 | 34.29 |
| .250 | 6.35 | .684 | 17.37 | .938 | 23.83 | 1.406 | 35.71 |
| .312 | 7.92 | .707 | 17.96 | .957 | 24.31 | 1.516 | 38.51 |
| .395 | 10.03 | .730 | 18.54 | .984 | 24.99 | 1.642 | 41.71 |
| .438 | 11.13 | .750 | 19.05 | 1.000 | 25.40 | 1.768 | 44.91 |
| .457 | 11.61 | .770 | 19.56 | 1.083 | 27.51 | 1.889 | 47.98 |
| .500 | 12.70 | .812 | 20.62 | 1.145 | 29.08 | | |

NOTES:

1. DIMENSIONS ARE IN INCHES AND APPLY AFTER PLATING.
2. METRIC EQUIVALENTS ARE GIVEN FOR GENERAL INFORMATION ONLY AND ARE BASED UPON 1.00 (25.4 mm).
3. CADMIUM, ZINC NICKEL OR PURE DENSE ELECTRODEPOSITED ALUMINUM/NICKEL INTERFACE SHALL BE COATED WITH POLYSULFIDE SEALANT. NOT APPLICABLE FOR FINISH 'L'.
4. PART SUPPLIED WITH STANDARD DETENTED SELF-LOCKING, WHICH PROVIDES A POSITIVE AUDIBLE DETENTED COUPLING. OPTION 'N' IS A FREE SPINNING SELF-LOCKING COUPLING.
5. RIBBED, INTERNAL KNURL OR SURFACE ROUGHNESS Ra 125-250 IN ACCORDANCE WITH ANSI B46.1. SEE FIGURE 2 FOR SELECTIVE PLATING DETAILS.
6. AREA FREE OF CADMIUM, ZINC NICKEL OR PURE DENSE ELECTRODEPOSITED ALUMINUM, AS APPLICABLE.

TABLE 1 - SHELL SIZE AND DIMENSIONS

| ACCESSORY SHELL SIZE | SHELL SIZE CODE | A MAX DIA | B DIA ±.010 ENTRY SIZE | | C DIA REF | | D MAX DIA | E MAX DIA | F (REF) |
|----------------------|-----------------|------------------|------------------------|------------------|-----------------|------------------|---------------|---------------|---------------|
| | | | 02 | 03 | 02 | 03 | | | |
| 9 | A | .858 (21.79) | N/A | .250 (6.35) | N/A | .395 (10.03) | 1.375 (34.93) | 1.417 (35.99) | 1.623 (41.22) |
| 11 | B | .984 (24.99) | N/A | .312 (7.92) | N/A | .457 (11.61) | 1.437 (36.50) | 1.480 (37.59) | 1.685 (42.80) |
| 13 | C | 1.157 (29.39) | .312 (7.92) | .438 (11.13) | .457 (11.61) | .583 (14.81) | 1.562 (39.67) | 1.553 (39.45) | 1.810 (45.97) |
| 15 | D | 1.279 (32.49) | .438 (11.13) | .562 (14.27) | .583 (14.81) | .707 (17.96) | 1.687 (42.85) | 1.614 (41.00) | 1.935 (49.15) |
| 17 | E | 1.406 (35.71) | .500 (12.70) | .625 (15.88) | .645 (16.38) | .770 (19.56) | 1.750 (44.45) | 1.678 (42.62) | 1.998 (50.75) |
| 19 | F | 1.516 (38.51) | .625 (15.88) | .750 (19.05) | .770 (19.56) | .895 (22.73) | 1.875 (47.63) | 1.773 (45.03) | 2.123 (53.92) |
| 21 | G | 1.642 (41.71) | .625 (15.88) | .812 (20.62) | .770 (19.56) | .957 (24.31) | 1.938 (49.23) | 1.796 (45.62) | 2.186 (55.52) |
| 23 | H | 1.768 (44.91) | .688 (17.48) | .938 (23.83) | .829 (21.06) | 1.083 (27.51) | 2.062 (52.37) | 1.859 (47.22) | 2.310 (58.67) |
| 25 | J | 1.889 (47.98) | .750 (19.05) | 1.000 (25.40) | .895 (22.73) | 1.145 (29.08) | 2.125 (53.98) | 1.919 (48.74) | 2.373 (60.27) |

REQUIREMENTS:

DESIGN AND CONSTRUCTION:

DIMENSIONS AND CONFIGURATION: SEE FIGURE 1 AND TABLE 1.

INTERFACE DIMENSIONS: SHALL CONFORM TO SAE AS85049, FIGURE 3.

COUPLING NUT: SHALL BE CAPTIVATED TO THE ADAPTER BODY AND ROTATABLE.

MATERIAL AND FINISH: IN ACCORDANCE WITH SAE AS85049 AND TABLE 2.

TABLE 2 - MATERIAL AND FINISH

| FINISH | MATERIAL |
|--|---|
| G – ELECTROLESS NICKEL <u>1/</u> (SPACE GRADE) N – ELECTROLESS NICKEL <u>1/</u> P – CADMIUM OLIVE DRAB OVER ELECTROLESS NICKEL, (SELECTIVE PLATING, SEE FIGURE 2) <u>2/</u> W – CADMIUM OLIVE DRAB <u>2/</u> X – NICKEL FLUOROCARBON POLYMER Z – ZINC NICKEL <u>2/</u> YP – PURE DENSE ELECTRODEPOSITED ALUMINUM OVER ELECTROLESS NICKEL (SELECTIVE PLATING, SEE FIGURE 2) ZP – ZINC NICKEL OVER ELECTROLESS NICKEL (SELECTIVE PLATING, SEE FIGURE 2) <u>2/</u> | ALUMINUM ALLOY IN ACCORDANCE WITH SAE AS85049 |
| J – CADMIUM OLIVE DRAB <u>2/</u> L – CADMIUM OLIVE DRAB OVER ELECTROLESS NICKEL, (SELECTIVE PLATING, SEE FIGURE 2) <u>2/ 3/</u> M – ELECTROLESS NICKEL XC – NICKEL FLUOROCARBON POLYMER YL – PURE DENSE ELECTRODEPOSITED ALUMINUM, SELECTIVE PLATING, SEE FIGURE 2) <u>3/</u> ZC – ZINC NICKEL <u>2/</u> ZL – ZINC NICKEL (SELECTIVE PLATING, SEE FIGURE 2) <u>2/ 3/</u> | COMPOSITE IN ACCORDANCE WITH SAE AS85049 |

1/ G AND N FINISH NOT FOR NAVY USE, RESTRICTED TO AIR FORCE SPACE APPLICATIONS ONLY.

2/ P, W, Z, ZP, J, L, ZC AND ZL FINISHES ARE NOT FOR USE IN SPACE APPLICATIONS. ALSO SEE SPECIFICATION NOTE

3/ MUST MEET THE REQUIREMENTS AND PASS TESTS FOR FINISH J.

| | | | |
|---|--|---------------------------------------|-------------------|
|  An SAE International Group | AEROSPACE STANDARD | SAE AS85049/90 SHEET 3 OF 4 | REV. B |
| | (R) CONNECTOR ACCESSORIES, ELECTRICAL, BACKSHELL, 90°, SELF-LOCKING, SHIELD BAND TERMINATION, (RF/EMI), SHRINK SLEEVE ACCOMMODATION, CATEGORY 3B (FOR MIL-DTL-38999 SERIES III AND IV CONNECTORS) | | |

TABLE 3 - TEST FLUIDS

| SAMPLE NUMBER | TEST FLUID (EIA 364-10) |
|---------------|-------------------------|
| 1 | A |
| 2 | B |
| 3 | C |
| 4 | D |
| 5 | E |
| 6 | F |
| 7 | G |
| 8 | H |
| 9 | I |
| 10 | K |

PART NUMBER: SEE EXAMPLE BELOW:

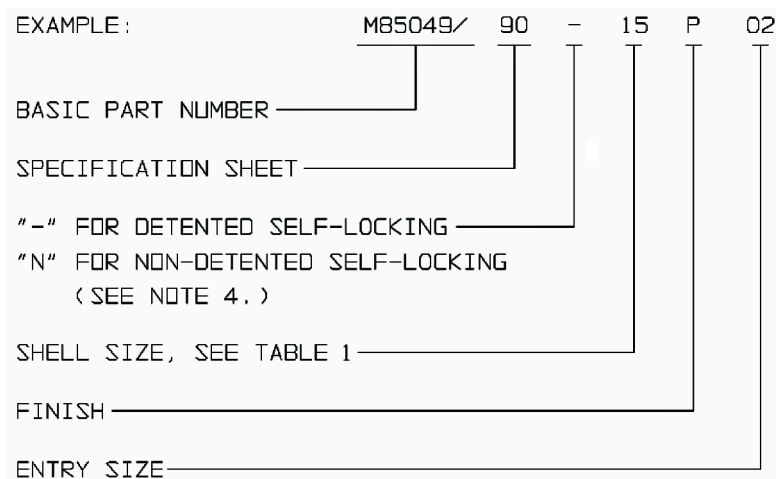

QUALIFICATION: SEE SAE AS85049, CATEGORY 3B.

SPECIFICATION NOTES:

NOTICE

THIS DOCUMENT REFERENCES A PART WHICH CONTAINS CADMIUM AS A PLATING MATERIAL. CONSULT LOCAL OFFICIALS IF YOU HAVE QUESTIONS CONCERNING CADMIUM'S USE.

A CHANGE BAR (I) LOCATED IN THE LEFT MARGIN IS FOR THE CONVENIENCE OF THE USER IN LOCATING AREAS WHERE TECHNICAL REVISIONS, NOT EDITORIAL CHANGES HAVE BEEN MADE TO THE PREVIOUS ISSUE OF THIS DOCUMENT. AN (R) SYMBOL TO THE LEFT OF THE DOCUMENT TITLE INDICATES A COMPLETE REVISION OF THE DOCUMENT, INCLUDING TECHNICAL REVISIONS. CHANGE BARS AND (R) ARE NOT USED IN ORIGINAL PUBLICATIONS NOR IN DOCUMENTS THAT CONTAIN EDITORIAL CHANGES ONLY.