

**EAT•N**

**Heinemann**

Heinemann® AM/R and AM1P Series  
Circuit Breakers

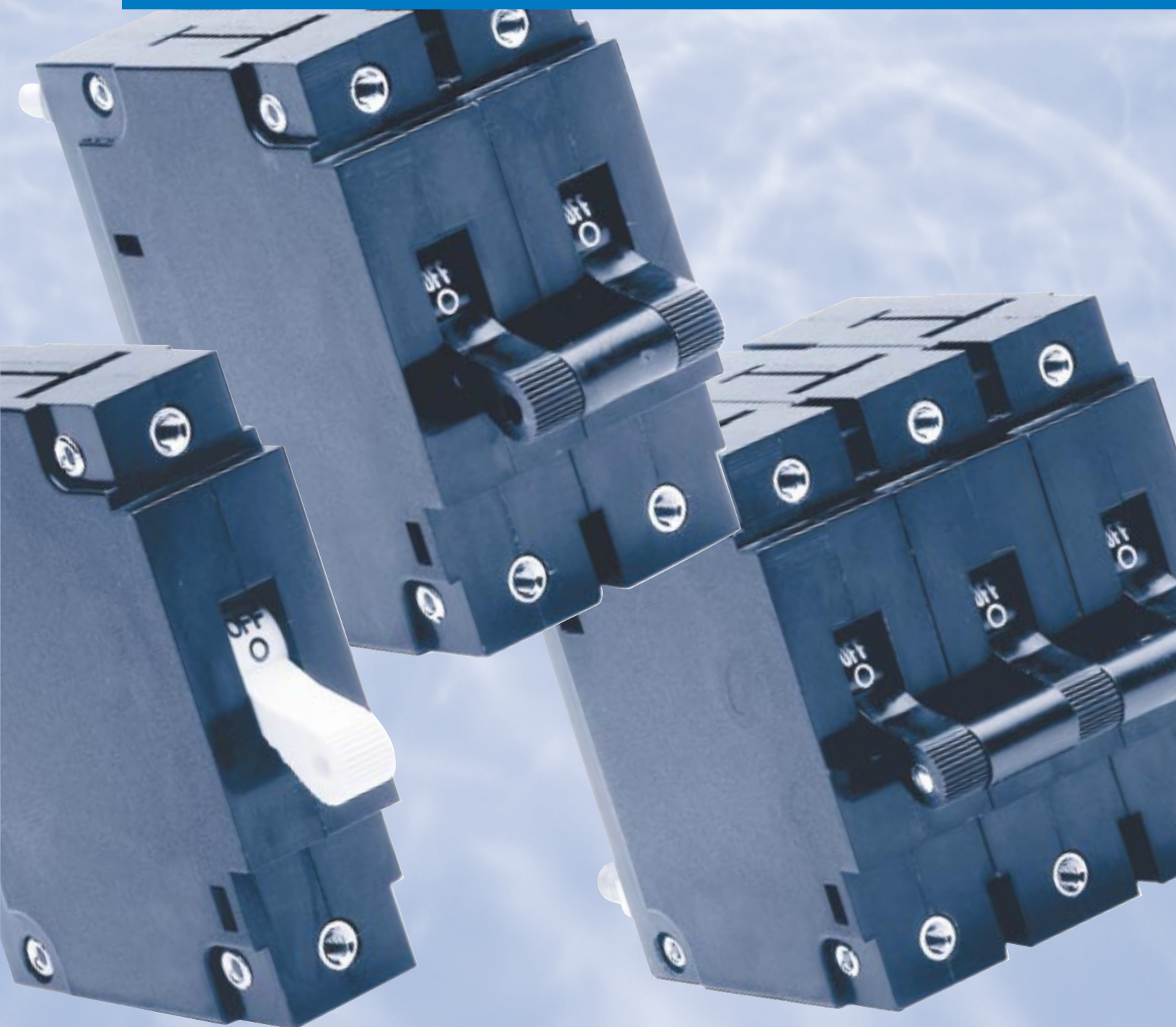

# HEINEMANN® CIRCUIT BREAKERS

## AM/R and AM1P Series Circuit Breakers

### DESCRIPTION

Heinemann® Series AM/R circuit breakers are the logical choice for high quality service entrance and panelboard installations, as well as control and protection. The precisely tailored time delays and ability to interrupt high currents make them ideal for critical applications.

### NEW – Enhanced Ratings with AM1P Series

Eaton's new line of AM1P Circuit Breakers are rated up to 200 A with 50,000 A interrupting capacity protection which makes it ideal for telecommunications sites with space constraints. The AM1P breaker was designed to be streamlined and durable featuring an improved arc structure that provides enhanced ratings and a high-strength, low shrink molding compound for added resilience in harsh environments. It is also a proprietary precision current equalization breaker (PCE) which helps prevent uneven current distributions unlike conventional parallel pole breakers. Therefore nuisance tripping is highly reduced. The AM1P Series is UL489A listed.



### UL489 LISTED / MEETS INTERNATIONAL STANDARDS

Heinemann® wrote the book on the HYDRAULIC MAGNETIC CIRCUIT BREAKERS by patenting the original technology back in 1932. Today, Eaton Corporation continues the tradition of technical leadership by introducing the latest innovation in the evolution

of the hydraulic magnetic circuit breaker – the rugged and versatile AM/R Series.

The AM/R is designed to be a “World Product” and solve the toughest equipment circuit protection problems around the globe. It combines the proven high quality and reliability of the former AM Series with the spacing, dielectric and interrupt requirements of International Standards. The AM/R is UL489 Listed and CSA Certified for industrial controls as a branch circuit breaker. It is also UL1077 Recognized for appliance protection. Available in a wide variety of configurations, the AM/R is rated as high as 100 A at 240 V AC or 80 V DC.

It is the solution for demanding DC applications requiring up to 50,000 A interrupting capacity.

### HYDRAULIC-MAGNETIC BENEFITS

The hydraulic-magnetic load-sensing and time delay mechanism of the AM/R Series is insensitive to changes in ambient or enclosure temperature, adapting it to service conditions encountered. Unlike thermal breakers, the AM/R can be loaded to rated capacity without causing nuisance tripping when ambient temperature rises.

### OPTIONS

- 1 to 8 pole models.
- Short, medium, slow or instantaneous response times to accurately match load conditions.
- Auxiliary switch for signaling.

### AM/R FEATURES:

- Current range up to 100 A 50/60 Hz, 60 A 400 Hz, 100 A DC.
- Available with AC/DC rating.
- Common trip on multi-pole breakers.
- UL and CSA Recognition and UL Listing available.

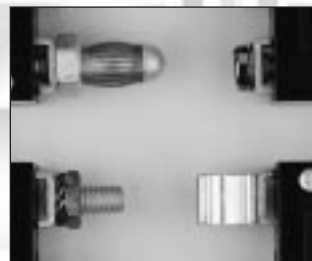

- International Standards approvals.
- Shock, vibration, humidity and moisture according to MIL-STD.
- Ignition protected.
- Tamper-proof terminals.
- Mid-trip alarm.
- Handles knurled for positive grip.
- Custom marked handles and colors.
- Replacement for previous AM and NAM/S models.

### SPECIFICATIONS

#### International Specifications

AM/R Series breakers are designed to meet the requirements of EN60947-2.

#### Maximum Current Rating

AM/R – Up to 100 A per pole.  
AM1P – Up to 200 A.

#### Terminal Types

Back-connected and many special terminals are available. Consult Application Engineering.

#### Multi-Pole Trip Construction

Multi-pole breakers incorporate true common trip construction. When an overload condition occurs on any pole, the mechanism of that pole actuates an internal tripper bar which is connected to and operates all poles simultaneously. Thus an overload condition on any pole causes all poles to trip.

#### Trip Curves

See page 6.

#### Operating Temperature

-40°C to +85°C.

**Environmental Data**

Designed to meet MIL-C-55629 as specified below.

**Fungus- and Moisture-Resistance**

Provided by treating all ferrous parts with a special moisture-resistant finish and by using special springs and inherently fungus-resistant cases, covers and handles.

Tested for moisture-resistance per MIL-STD-202, Method 106; tested for salt-spray resistance per MIL-STD-202, Method 101.

**Humidity**

Tested in accordance with MIL-STD-202, Method 103, test condition A.

**Shock**

Tested for shock in accordance with MIL-STD-202, Method 213, test condition I (100 G's at 6 milli-seconds).

**Vibration**

Tested for vibration in accor-

dance with MIL-STD-202, Method 204: 10 to 500 Hz, 1,5 mm (0.06") total excursion on three mutually perpendicular planes. Shock and vibration tests are conducted with breakers carrying full rated current. Shock and vibration specifications apply to time-delay breakers only.

**Life**

Breakers are subjected to an endurance test consisting of 10,000 On/Off operations.

100 A or less: 6000 at rated current and voltage, 4000 at no load

101-200 A: 4000 at rated current and voltage, 4000 at no load.

**Approximate Weights**

- 1 pole, 100 g; 3 oz.
- 2 poles, 200 g; 6.5 oz.
- 3 poles, 300 g; 9.5 oz.
- 4 poles, 400 g; 12.5 oz.

**Dielectric Strength**

Tested in accordance with MIL-STD-202, Method 301;

1500 V at 50/60 or 400 Hz, 1100 V DC (or twice rating plus 1000 V).

Meets 8mm international spacing and 3750 V 50/60 Hz dielectric requirements from hazardous voltage to operator accessible surfaces, between adjacent poles and from main circuit to auxiliary circuit.

**Insulation Resistance**

100 Megaohms minimum at 500 V DC, per MIL-STD-202, Method 302.

**Impedance**

(Internal Resistance) See impedance chart on page 4. Impedance or internal resistance across cold breaker at full rated load.

**Flammability Specifications**

UL 94-V0, UL 94-HB

**APPROVALS**



TABLE OF CONTENTS		Page
<b>Description</b> .....		2
<b>Specifications</b> .....		2-4
<b>Trip Curves</b> .....		6-10
<b>Internal Circuits</b> .....		11-13
<b>Dimensions</b> .....		14-17
<b>How to Order</b> .....		18-21
<b>Additional Products</b> .....		22

The technical information published in this handbook is subject to change without prior notice. Modifications may occur as part of continual improvement of our products. For up-to-date information, please contact our Customer Service Center at 1-800-962-0820.

# HEINEMANN® AM/R AND AM1P SERIES CIRCUIT BREAKERS

## Specifications

AM/R AND AM1P AGENCY APPROVALS						
Standard	Voltage	Frequency ①	Phase/Pole Spaces	Current Range	Standard Interruption ④	High Capacity ④
UL 489 CSA	80 VDC	—	DC/1	0.02 – 100	5,000	50,000@65VDC
	120 VAC	50-60	1/1	0.02 – 20	5,000	7,500
	120 VAC	50-60	1/1	21 – 50	5,000	—
	120/240 VAC	50-60	1/2	0.02 – 20	5,000	7,500
	120/240 VAC	50-60	1/2	21 – 50	5,000	—
UL 489a	80 VDC	—	DC/1	0.02 – 100	5,000	50,000@65VDC
	80 VDC	—	DC/2	101 – 150	10,000	50,000@65VDC
	80 VDC	—	DC/3	151 – 200	10,000	50,000@65VDC
UL1077 CSA	80 VDC	—	DC/1	0.01 – 100	7,500	—
	120/240 VAC	50-60	1/2	0.02 – 100	3,000	—
	240 VAC	50-60	1 & 3/1 & 3	0.02 – 100	5000 ②	—
	80 VDC 240 VAC	50-60	1 & 3/1 & 3	0.02 – 100	5000 ②	—
	240/415 VAC	50-60	3	.1 – 50	5000 ③	—
	277/480 VAC	50-60	3	.1 – 30	5000 ③	—
	277 VAC	50-60	1	.1 – 50	5000 ②	—
	240 VAC	50-60	1 & 3	.1 – 50	1,500	—
Switch only per UL508	80 VDC	—	DC	.02 – 100	—	—
	415 VAC	50-60	3	.02 – 50	—	—
	240 VAC	50-60	1 & 3	.1 – 100	—	—
	277 VAC	50-60	1	.02 – 50	—	—
	277/480 VAC	50-60	3	.1 – 30	—	—
Marine Ignition UL 1500	240 VAC	50-60	1	.1 – 75	2000 ②	—
	65 VDC	—	DC	.1 – 60	2000 ②	—
	65 VDC 240 VAC	50-60/DC	1 & 3	.1 – 60	2000 ②	—
TUV	80 VDC	—	DC	.1 – 70	5000	—
	80 VDC	—	DC	70.1 – 100	1500	—
	240/400 VAC	50-60	3	.1 – 50	1500 ⑤	—

- ① DC and 1 Phase 277 V max ratings are 1 or 2 pole breaking. 3 phase ratings are 3 pole breaking
- ② Requires branch circuit backup with UL listed type K5 fuse rated (15A minimum) at no more than 175A for 51 thru 100A rating

- ③ UL recognized/CSA certified. Refers to 3 and 4 pole versions used only in a 3 phase, WYE connection with series fusing as stated in note ②.
- ④ A clearance of 1 inch for DC and 2 inches for AC is required between the arc vent and conductive surfaces or components.
- ⑤ TUV Certification at 400 volts.

RESISTANCE AND IMPEDANCE VALUES	
Tolerance Limits Current (amps)	Tolerance (%)
0.1 to 19.9	±25
20 to 100	±35

Nominal DCR and Impedance							
Current Rating Amps	DC Delays (Resistance in Ohms)			60 Hz Delays (Impedance in Ohms)			400 Hz Delays (Impedance in Ohms)
	P-2-3 10-20-30	Curves 251-252-253	DuCon 2-3-20-30	P-2-3 10-20-30	Curves 251-252-253	DuCon 2-3-20-30	Curves P-1-2-3
0.05	447	730	730	418	836	809	744
0.10	127	182	174	139	176	186	200
0.5	4.12	7.0	6.4	3.99	7.3	6.4	9.36
1	.86	1.65	1.67	.917	1.580	1.780	1.74
5	.050	.069	.069	.051	.073	.068	.074
10	.014	.0181	.0177	.016	.0172	.0158	.021
15	.0059	.0164	.0146	.0060	.0162	.0155	.0101
20	.0045	.0068	.0067	.0046	.0067	.0068	.0060
30	.0031	.0028	.0019	.0031	.0031	.0029	.0037
50	.0017	.0020	.0019	.0017	.0020	.0019	.0024
70	.0007			.0007			
100	.0006			.0006			

DCR and impedance based on 100% rated current applied and stabilized a minimum of one hour.  
Tolerance 0.02 amps to 2.5 amps ±20%, 2.6 amps to 20 amps ±25% 21 amps to 100 amps ±50%.

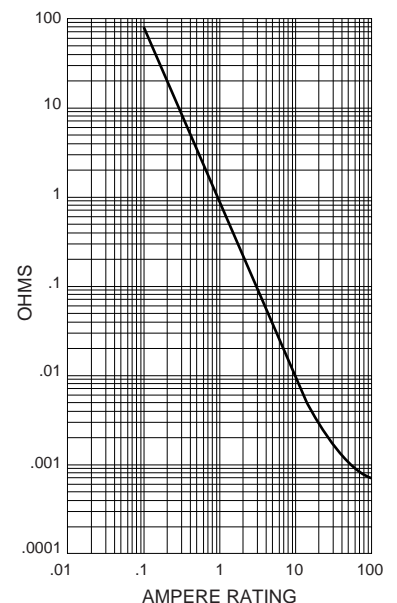

## PRECISE OVERLOAD PROTECTION — WITH HEINEMANN® HYDRAULIC-MAGNETIC CIRCUIT BREAKERS

### Heat-induced nuisance tripping eliminated

Heinemann® hydraulic-magnetic circuit breakers offer three major advantages over thermal devices:

1. Reduces nuisance tripping caused by high ambient temperature in or near the installation. The breaker responds only to current variations, not to temperature change.
2. Assurance that 100% of the rated current will be carried. There is no such assurance with thermal devices, which may fail to carry rated current when subjected to above-normal ambient temperatures. A Heinemann® breaker rated at 20 A, for example, will sustain 20 A, even at elevated temperatures. Derating and other forms of temperature compensation are unnecessary.
3. Immediate reset. Since there are no thermal elements, heat build-up is not a factor.

Therefore, no "cooling off" period is required after fault interruption.

### Time delay eliminates breaker tripping due to transient current surges

Elimination of transient current surges as a cause of nuisance tripping is accomplished through the creation of a controlled time delay. In any installation where a power supply or compressor motor is on the line, an inrush of current occurs when the equipment is first turned on. The bigger the equipment, the larger the surge. Although inrush surges are, in fact, transient overloads, they usually pose no threat of damage to the line or to the equipment. So it is not necessary or even desirable to interrupt the power when they occur.

The hydraulically-controlled time-delay mechanism of a Heinemann® breaker eliminates nuisance tripping without lessening overload

protection. The delay is inversely proportional to the overload; response is quicker on large overloads, where greater potential danger exists, and slower on small overloads. Except in special high-inrush models, heavy overload and short-circuit currents of greater than 10 times the breaker's rating provide instantaneous response. (An instantaneous-trip breaker is available for use on, for example, modern medical and communication equipment, which cannot tolerate even brief overloads.)

For added protection, the time-delay is self-adjusting to ambient temperature conditions. At high ambients, where the overload tolerance of most circuits is lowered, the viscosity of the special fluid in the breaker's dashpot is lessened, and the time-delay response is correspondingly longer to allow cold-equipment startups.

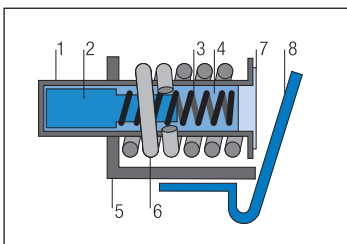

Circuit Breaker with No Load

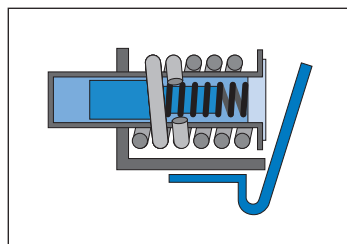

Circuit Breaker Slightly Overloaded

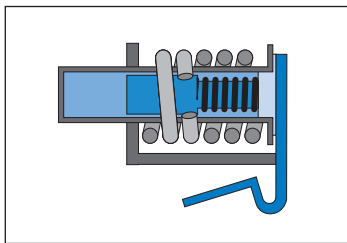

Circuit Breaker Overloaded

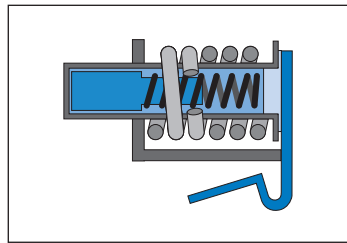

Circuit Breaker Severely Overloaded

Hydraulic-magnetic circuit breaker parts:

- |          |                  |               |
|----------|------------------|---------------|
| 1. Tube  | 2. Core          | 3. Spring     |
| 5. Frame | 6. Coil (sensor) | 7. Pole piece |

- |          |             |
|----------|-------------|
| 4. Fluid | 8. Armature |
|----------|-------------|

# HEINEMANN® AM/R AND AM1P SERIES CIRCUIT BREAKERS

## TRIP CURVE EXPLANATION

### Tripping Specifications

Breakers (in standard wall-mounted position) shall hold 100% rated current. For table and ceiling mount – consult Application Engineering.

### 50/60 Hz or DC

Breakers may trip between 101% and 125% rated load; must trip at 125% rated load and above, as shown on time-delay curve selected.

### AC/DC

Breakers may trip between 101% and 135% rated load; must trip at 135% rated load and above.

### 400 Hz

Breakers may trip between 101% and 150%, must trip at 150% and above.

### Non-Time Delay Trip Ranges

Breakers that have no deliberately imposed delay (less than 100ms) are specified as follows.

Breakers shall hold 100% rated current.

Breakers for 50/60 Hz or DC service may trip between 101% and 125% rated current, must trip at 125% rated current and above.

Breakers for AC/DC service may trip between 101% and 135% rated load; must trip at 135% rated load and above.

Breakers for 400 Hz service may trip between 101% and 150% rated current, must trip at 150% rated current and above.

**Note:** All the curves shown describe breaker response with no pre-loading. (Breakers do not carry current prior to application of overload for calibration testing.) Curves are plotted at an ambient temperature of 25°C (77°F), with breakers in the standard wall-mounted position.

Inrush	Time Delay Curve vs. Percent of Rated Current															
	Curve	100%	125%	135%	150%	200%	300%	400%	500%	600%	700%	800%	900%	1000%	1100%	1200%
50/60 Hz 8x	1	No trip	50-700	–	32-350	10-90	–	1.50-15	–	.5-7	–	.02-3	–	.006-2	–	.005-1
	2	No trip	10-100	–	4.5-50	1.7-18	.55-6	.25-2.8	.11-1.9	.05-1.5	.025-1.2	.015-.80	.011-.41	.01-.20	.009-.10	.008-.05
	3	No trip	1-12	–	.40-5	.15-1.9	.054-.64	.03-.30	.017-.20	.01-.14	.007-.09	.005-.06	.004-.05	.004-.05	.004-.046	.004-.04
50/60 Hz 18x	4	No trip	60-700	–	30-350	10-120	3.4-42	2.0-22	1.1-12.5	.50-8	.17-5.2	.05-4	.02-3.4	.01-3	.008-2.5	.008-2
	5	No trip	10-110	–	4.5-50	1.7-18	.54-6.9	.30-4	.18-2.75	.10-2	.04-1.4	.02-1	.013-.75	.01-.50	.01-.25	.01-.10
	6	No trip	1-12	–	.40-5	.15-1.9	.052-.73	.03-.40	.02-.27	.015-.20	.012-.14	.01-.10	.008-.074	.006-.06	.005-.053	.005-.05
50/60 Hz 25x	7	No trip	75-400	–	35-170	15-70	5-25	3-15	2-9.5	1.5-8	.9-7	.5-6	.4-5	.3-5	.2-5	.1-4
	8	No trip	10-100	–	6-55	2.5-20	.85-4.5	.45-2.5	.30-1.8	.22-1.6	.15-1.5	.10-1.4	.08-1.2	.07-1	.06-.90	.05-.70
	9	No trip	1-17	–	.40-4.5	.16-1.6	.06-.46	.05-.40	.04-.35	.03-.30	.025-.25	.020-.22	.015-.20	.012-.15	.009-.12	.008-.08
DC 8x	1	No trip	45-345	–	20-150	9-60	3-20	1.4-11.4	.45-7.5	.15-5.8	.03-4.5	.009-3.7	.006-2.6	.005-1.7	.005-.90	.005-.50
	2	No trip	6-80	–	2.5-30	.80-10	.25-3.7	.15-2	.09-1.2	.05-.80	.021-.50	.01-.30	.006-.17	.005-.10	.004-.06	.004-.04
	3	No trip	1-12	–	.40-5.0	.15-1.9	.054-.64	.03-.30	.017-.20	.01-.14	.007-.09	.005-.06	.004-.052	.004-.05	.004-.046	.004-.04
DC 18x	4	No trip	60-700	–	30-350	10-120	3.4-42	2-22	1.1-12.5	.50-8	.17-5.2	.05-4	.02-3.4	.01-3	.008-2.5	.008-2
	5	No trip	10-110	–	4.5-50	1.7-18	.54-6.9	.30-4	.18-2.75	.10-2	.04-1.4	.02-1	.013-.75	.01-.50	.01-.25	.01-.10
	6	No trip	1-12	–	.40-5.0	.14-1.9	.052-.73	.03-.40	.02-.27	.015-.20	.012-.14	.01-.10	.008-.074	.006-.06	.005-.053	.005-.05
DC 25x	7	No trip	75-400	–	35-170	15-70	5-25	3-15	2-9.5	1.5-8	.9-7	.5-6	.4-5	.3-5	.2-5	.1-4
	8	No trip	10-100	–	6-55	2.5-20	.85-4.5	.45-2.5	.3-1.8	.2-1.6	.15-1.5	.10-1.4	.08-1.2	.07-1.1	.07-1	.06-.9
	9	No trip	1-17	–	.4-4.5	.16-1.6	.06-.46	.05-.4	.04-.35	.03-.3	.025-.25	.02-.22	.015-.2	.012-.15	.009-.12	.008-.08
400 Hz 8x	1	No trip	–	–	30-350	10-120	3.4-35	2-25	.86-19	.25-10	.06-2.6	.02-.60	.012-.25	.01-.15	.008-.12	.008-.10
	2	No trip	–	–	6-70	2.5-26	.85-8.5	.40-5	.23-3.1	.10-2	.02-1.1	.01-.60	.01-.30	.01-.15	.009-.085	.008-.05
	3	No trip	–	–	.60-7	.20-2.3	.075-.84	.04-.50	.02-.37	.01-.25	.006-.18	.005-.12	.004-.075	.004-.05	.004-.042	.004-.04
50/60 Hz DC 8x	1	No trip	–	35-520	20-350	9-90	3-26	1.4-15	.45-10	.15-7	.03-4.8	.009-3.7	.006-2.5	.005-2	.005-1.6	.005-1
	2	No trip	–	7.0-80	4.5-50	1.7-18	.55-6	.25-2.8	.11-1.9	.05-1.5	.025-1.2	.015-.80	.011-.41	.01-.20	.009-.10	.008-.05
	3	No trip	–	.60-9	.40-5	.15-1.9	.054-.64	.03-.30	.017-.20	.01-.14	.007-.09	.005-.06	.004-.052	.004-.05	.004-.046	.004-.04
50/60 Hz DC 18x	4	No trip	–	45-500	30-350	10-120	3.4-42	2-22	1.1-12.5	.50-8	.17-5.2	.05-4	.02-3.4	.01-3	.008-2.5	.008-2
	5	No trip	–	7-80	4.5-50	1.7-18	.54-6.9	.30-4	.18-2.75	.10-2	.04-1.4	.02-1	.013-.75	.01-.50	.01-.25	.01-.10
	6	No trip	–	.60-9	.40-5	.15-1.9	.052-.73	.03-.40	.02-.27	.015-.20	.012-.14	.01-.10	.008-.074	.006-.06	.005-.053	.005-.05
50/60 Hz DC 400 Hz	Instant. Delay "P" Max. Time	No trip	.100	.060	.050	.034	.020	.015	.012	.011	.011	.011	.011	.011	.011	.011

## TRIP CURVE EXPLANATION Time Delay Curve Selection

1. Determine required frequency.
2. Determine required high-inrush tolerance (tolerance to starting surges caused by high-resistance loads such as ferro-resonant power supplies which may last up to 10 milliseconds – 8 at 60 Hz). Select lowest high-inrush tolerance compatible with application.
3. Determine required curve characteristics based on application:

### Long Time Delay Curve

Motor starting, locked rotor tolerance, general purpose applications.

### Medium Time Delay Curve

Transformer protection, capacitor loads, special incandescent lamp loads, general purpose applications (most widely used curve).

### Short Time Delay Curve

Electronic equipment.

### Instantaneous Curve

(no deliberate time delay

provided) Unusual circumstances in electronic equipment and other special applications. The magnetic shunt used offers maximum possibilities on half wave which is 10 ms when frequency is 50 Hz.

### High-Inrush

Influence of line frequency is shown below.

For high-inrush rates, see graph below. For curve P, high-inrush is not possible.

## TRIPPING SPECIFICATIONS

Frequency				High-Inrush Tolerance			Curve Characteristics				Curve No
50/60 Hz	400 Hz	DC	AC/DC	8X	18X	25X	Long	Medium	Short	Inst.	
•	•	•	•	•			•	•			1
•	•	•	•	•					•		2
•	•	•	•	•						•	3
•	•	•	•		•		•	•			4
•	•	•	•		•			•			5
•	•	•	•		•				•		6
•		•				•	•				7
•		•				•		•			8
•		•				•			•		9
•	•	•	•							•	P

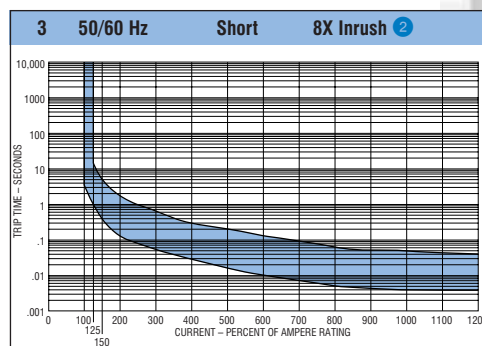
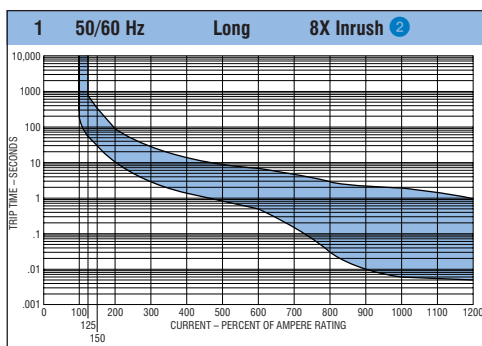
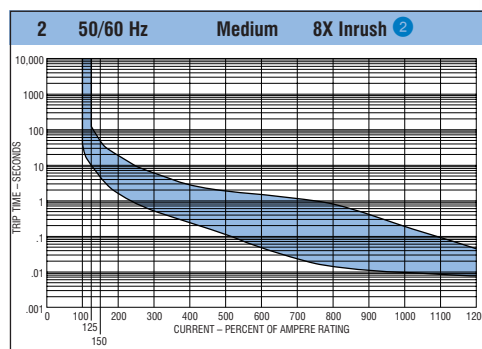
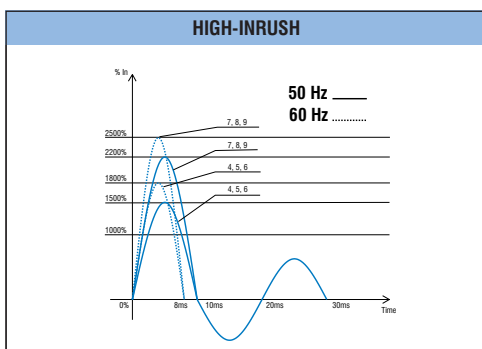

② Not available with AM1P series.

# HEINEMANN® AM/R AND AM1P SERIES CIRCUIT BREAKERS

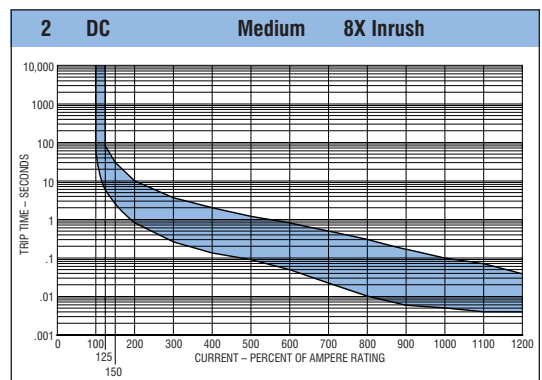
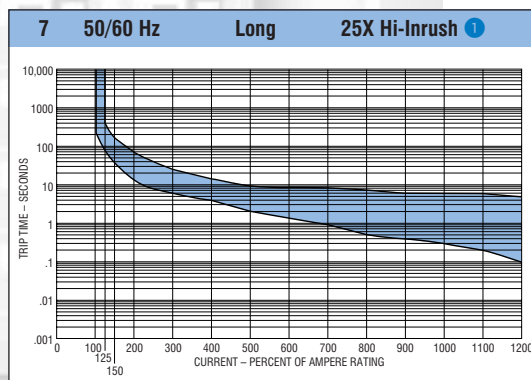
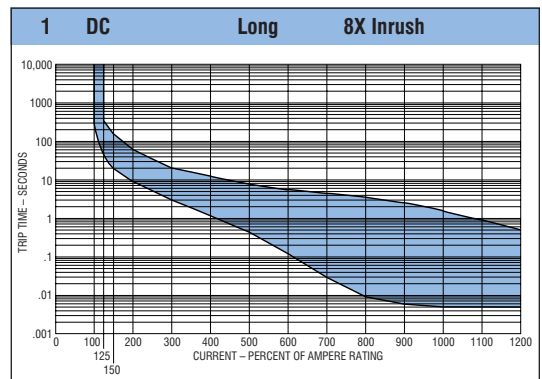
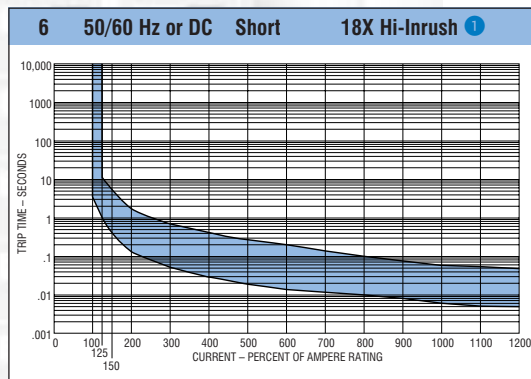
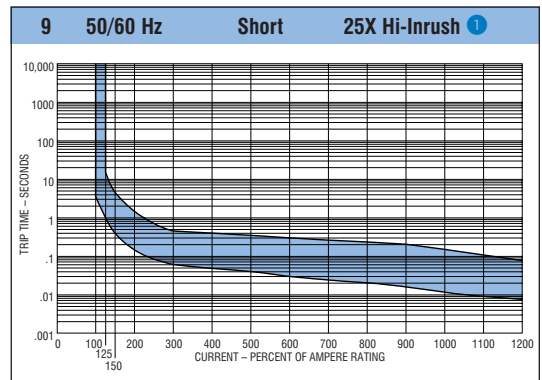
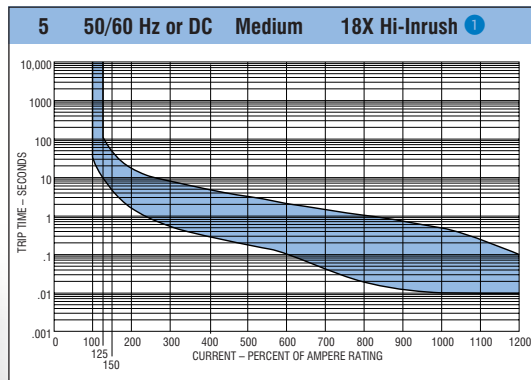
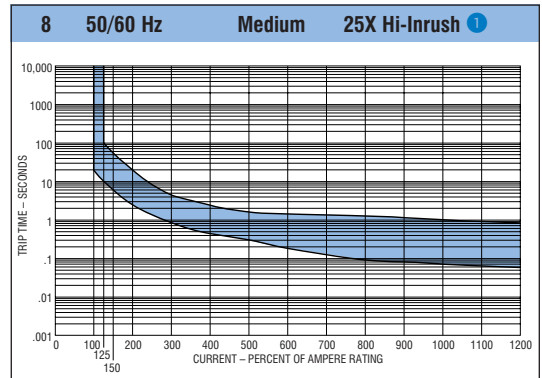
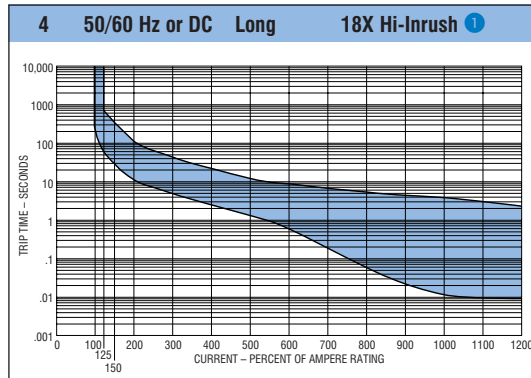

① Not available with AM1P series.

## Time delay curves

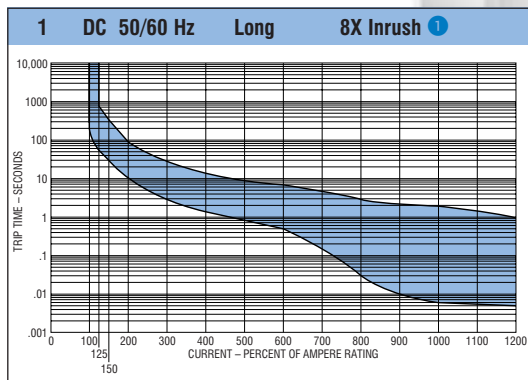
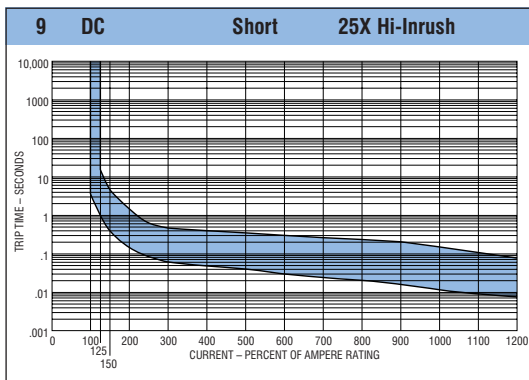
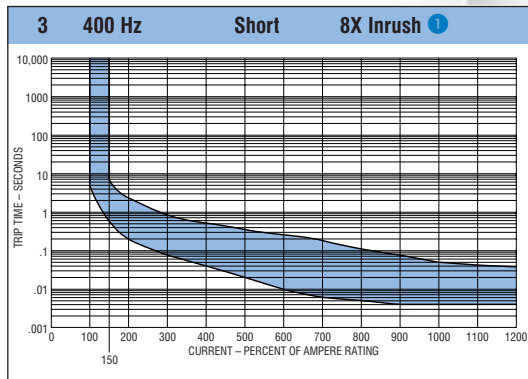
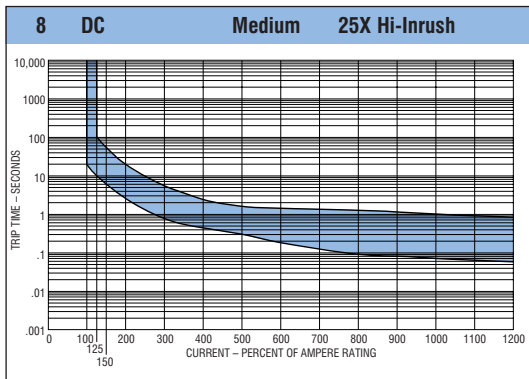
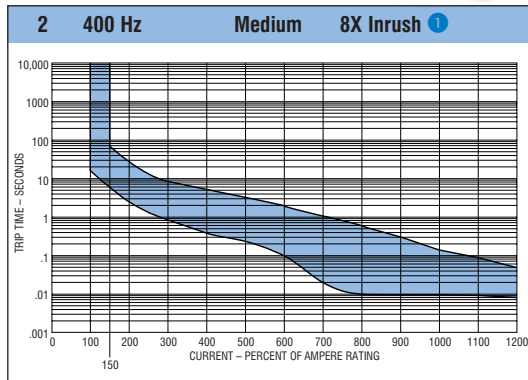
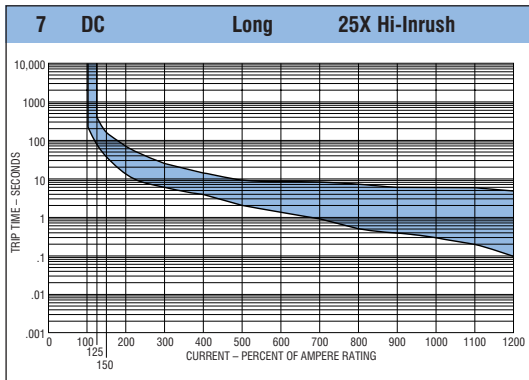
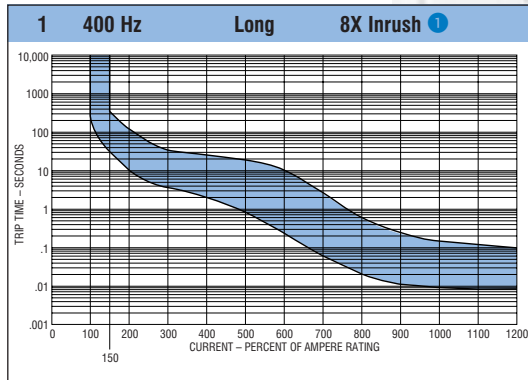
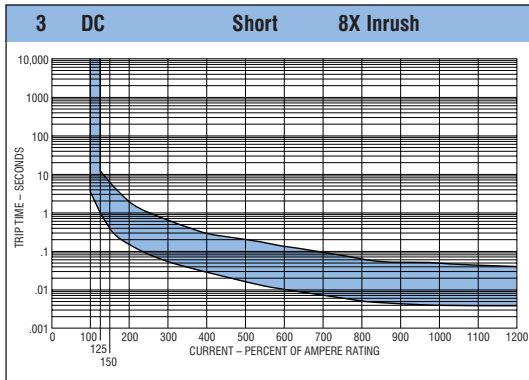

① Not available with AM1P series.

# HEINEMANN® AM/R AND AM1P SERIES CIRCUIT BREAKERS

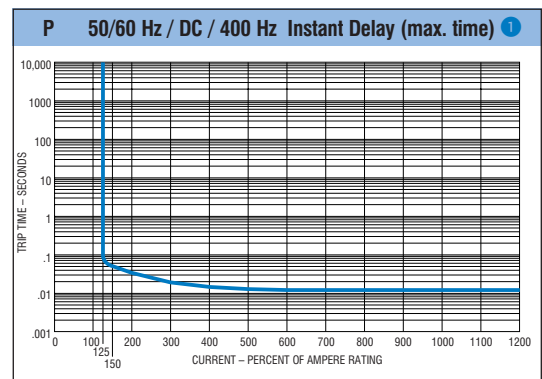
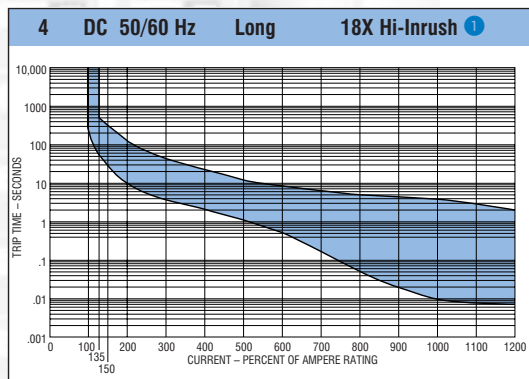
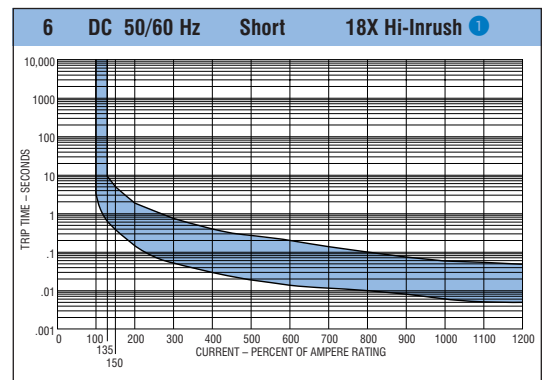
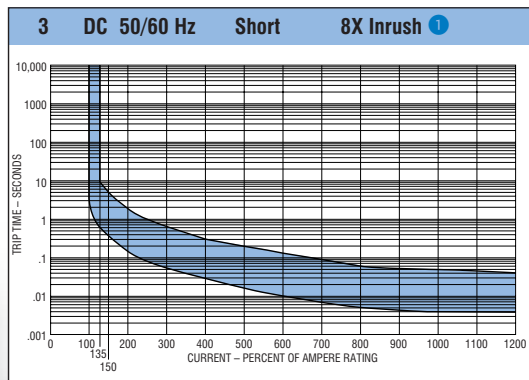
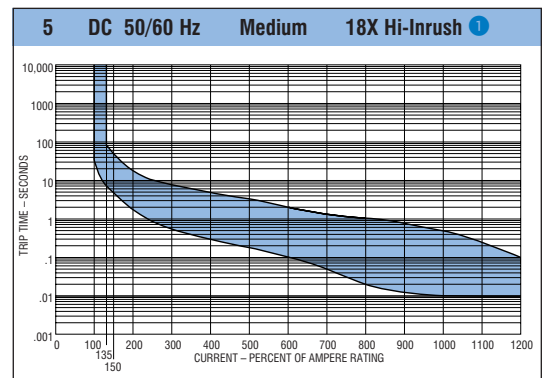
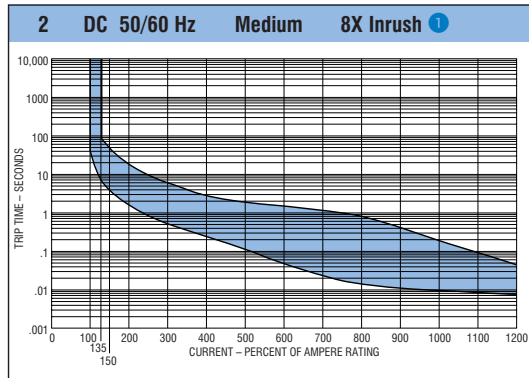

① Not available with AM1P series.

# Internal Circuits



Circuit	Diagrams	Description	Auxiliary Contact	Inrush	Internal Circuit Codes
Switch	<p>Internal Circuit represented: 12</p>	<p>Switch only (without coil) with or without auxiliary contact.</p>	No	No	<b>0</b> <sup>1</sup>
			Yes	No	<b>12</b> <sup>1</sup>
Series Trip	<p>Internal Circuit represented: 3, 8, 38</p>	<p>The contacts and the coil are in series. This is the standard execution of the AM/R circuit breaker. It is often used as main switch at the same time.</p>	No	8X	<b>3</b>
			No	18X	<b>8</b>
			No	25X	<b>38</b>
Series Trip With Auxiliary Contact	<p>Internal Circuit represented: 2, 9, 39</p>	<p>The contacts and the current sensing coil are in series. Auxiliary contacts are placed behind the circuit breaker and mechanically connected to the releasing system.</p>	Yes	8x	<b>2</b>
			Yes	18x	<b>9</b>
			Yes	25x	<b>39</b>
Shunt Trip	<p>Internal Circuit represented: 5, 22, 32</p>	<p>Enables two loads to be checked by means of a single circuit breaker. However it only releases if there is an overload in the main circuit – (2)A. The sum of the two nominal currents must not exceed the peak current of the contacts. With this execution, it is also possible to adjust the tripping through a potentiometer between the load terminals.</p>	No	8X	<b>5</b>
			No	18X	<b>22</b>
			No	25X	<b>32</b>

<sup>1</sup> Not available with AM1P series.

# HEINEMANN® AM/R AND AM1P SERIES CIRCUIT BREAKERS

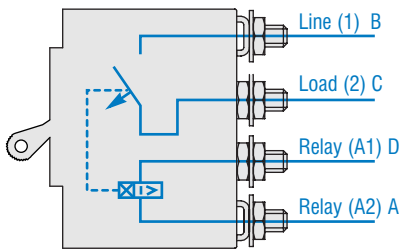
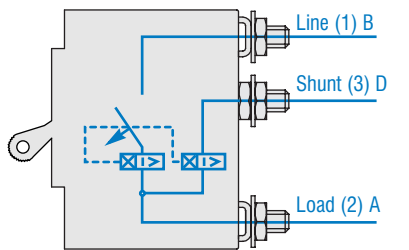
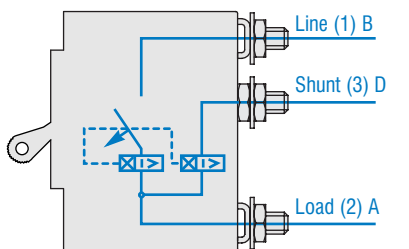
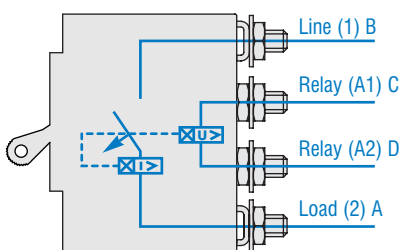
Circuit	Diagrams	Description	Auxiliary Contact	Inrush	Codes
Relay Trip	<p>Internal Circuit represented: 6, 23, 33</p> 	<p>Relay tripping can be used for releasing the circuit breaker by the intermediary of a monitor or a safety device installed at a distance. The contacts are electrically separated from the coil. Consequently, all the currents and voltages within the permissible limits can be used. Coils are either current or voltage sensitive. The circuit breaker can be supplied on request with a dielectric strength ranging up to 2500 V on alternating current 50/60 Hz between the coil and the contacts.</p>	No	8x	<b>6</b> <sup>1</sup>
			No	18x	<b>23</b>
			No	25x	<b>33</b> <sup>1</sup>
Dual Rating	<p>Internal Circuit represented: 7, 27, 37</p> 	<p>Dual rating circuit breakers are suitable for apparatus operating under two different currents or voltages. For example, same breaker may be used in USA (110 V AC) or Europe (220 V AC). As far as possible, the currents must be in the ratio of one to two with a maximum of 15 to 30 A.</p>	No	8X	<b>7</b> <sup>1</sup>
			No	18X	<b>27</b>
			No	25X	<b>37</b> <sup>1</sup>
Dual Control (Ducon)	<p>Internal Circuit represented: 15, 25</p> 	<p>This version is used both for the protection of the load finding itself in series with the circuit breaker and for the release via a voltage. The main coil is in series with the contact and the Ducon coil is shunt trip.</p>	No	8x	<b>15</b>
			No	18x	<b>25</b> <sup>1</sup>
Dual Control Ducon (Series + Relay)	<p>Internal Circuit represented: 16, 26</p> 	<p>Same function as codes 15 and 25, but both coils are electrically separated from main contact.</p>	No	8x	<b>16</b>
			No	18x	<b>26</b>

<sup>1</sup> Not available with AM1P series.

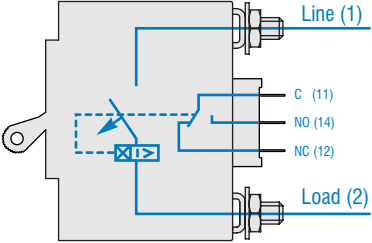
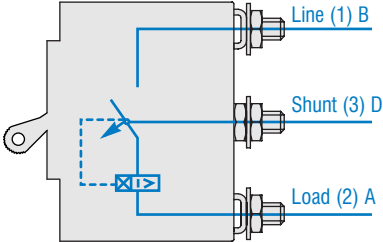
Circuit	Diagrams	Description	Auxiliary Contact	Inrush	Codes
Relay Trip (safety execution)	<p>Internal Circuit represented: 76, 86, 96</p> 	<p>These internal circuits have no main contact. When combined with another pole, they permit compliance with the safety regulations dictated by IEC 950.</p> <p>The required minimum creep distance between two galvanically separated electric circuits can thus be attained.</p>	No	8x	76 <sup>1</sup>
			No	18x	86 <sup>1</sup>
			No	25x	96 <sup>1</sup>
Mid-Trip	<p>Internal Circuit represented: 98, 99, 79</p> 	<p>Series overload. Mid-trip handle position.</p>	No	8x	98
			Yes	8x	99
			Yes	18x	79 <sup>1</sup>

<sup>1</sup> Not available with AM1P series.



APPROXIMATE IN MM (INCHES)

## 2, 3 AND 4 POLE PANEL CUTOUT ① ②

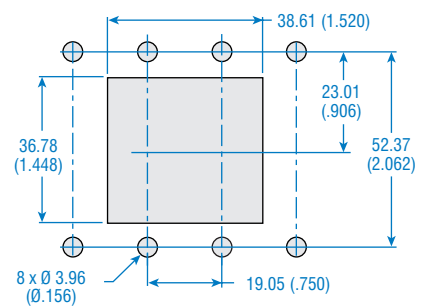
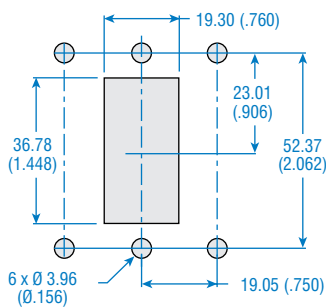
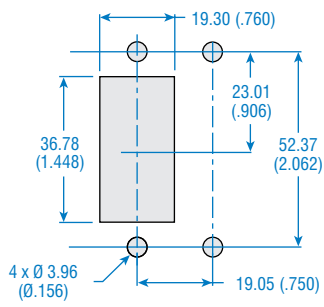
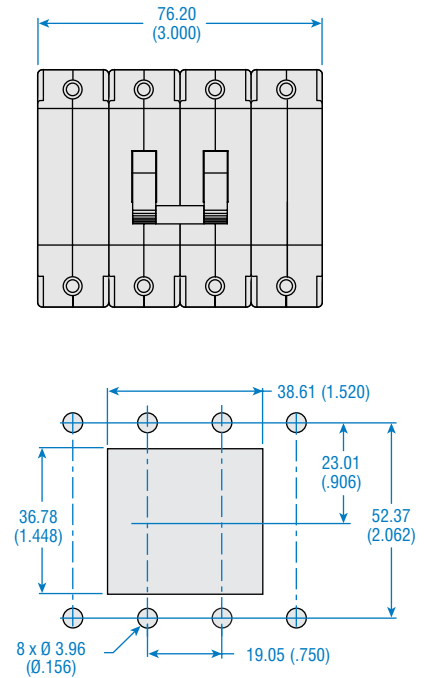
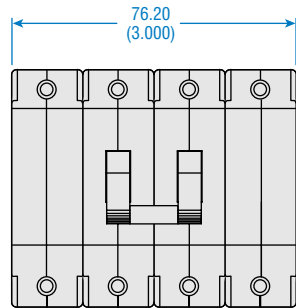
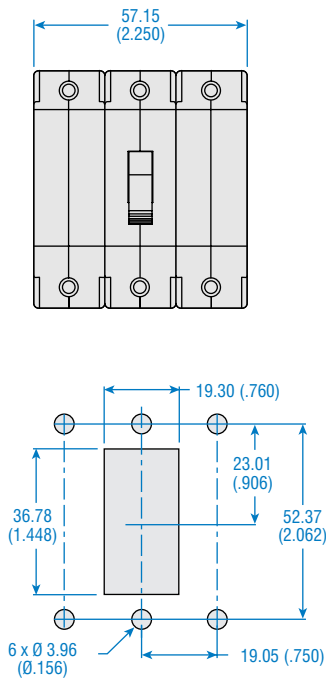
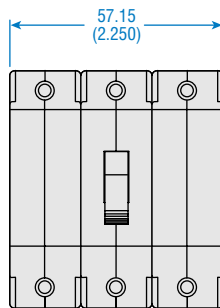
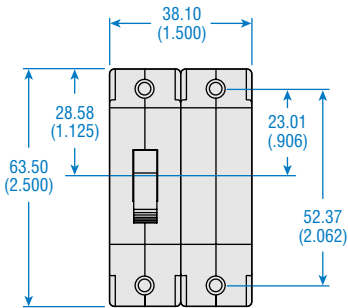
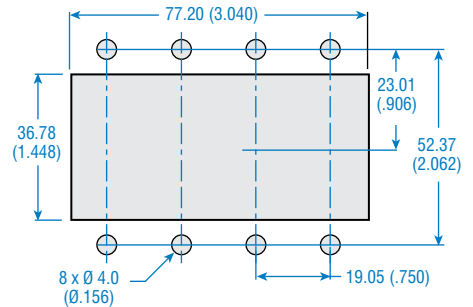
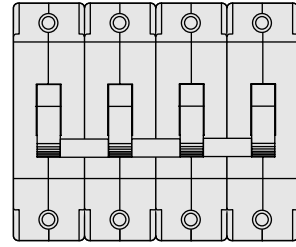
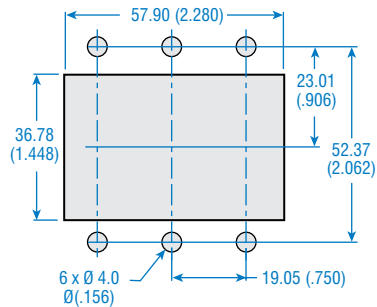
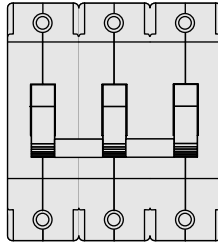
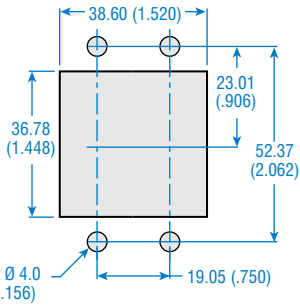
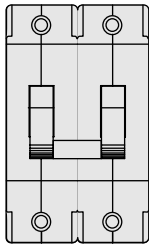

- ① M3 mounting inserts, 2 per pole, 5 mm (.195) deep clearance recess provided in moldings for mounting screw threads (also available with 6-32 mounting inserts).
- ② 1 and 4 pole versions not available with AM1P Series.

# HEINEMANN® AM/R AND AM1P SERIES CIRCUIT BREAKERS

## Dimensions

APPROXIMATE IN MM (INCHES)

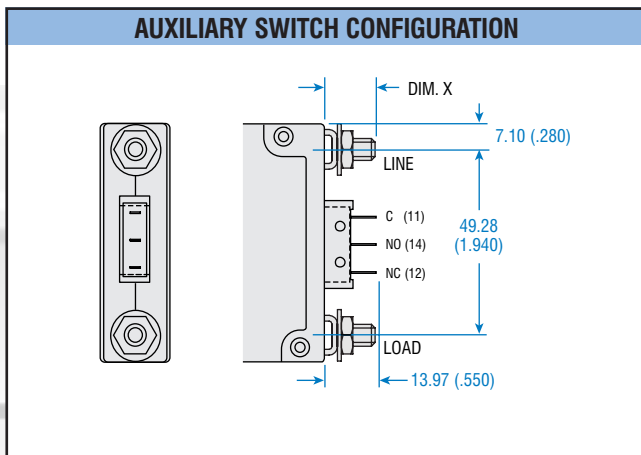
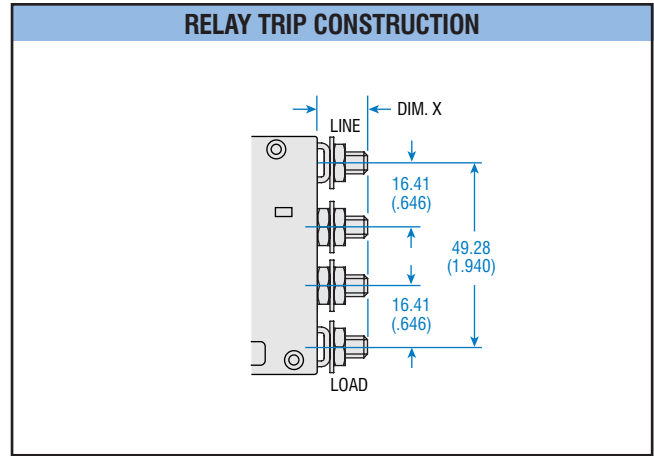
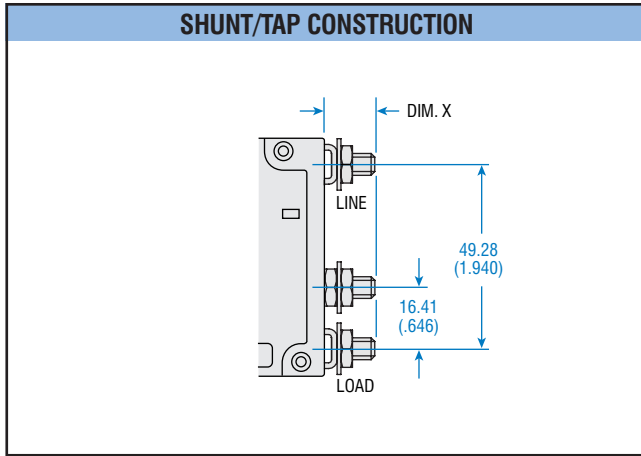

### Line Load Terminal Chart (standard length) ①

Terminal	0-70 A	71-100 A
Ø Metric	M5 x 0,8	M6 x 1
Length "X"	20,63 (.812)	21,64 (.852)
Ø Inches	10-32	1/4-20
Length "X"	16,26 (.640)	17,65 (.695)

### Torque Specifications

Dimensions	Torque allowed
Inserts M3; 6-32	0,6-0,8 Nm (5-7 in.-lb.)
Terminals M5; 10-32	1,7-2,3 Nm (15-20 in.-lb.)
Terminals M6; 1/4-20	3,4-4,0 Nm (30-35 in.-lb.)

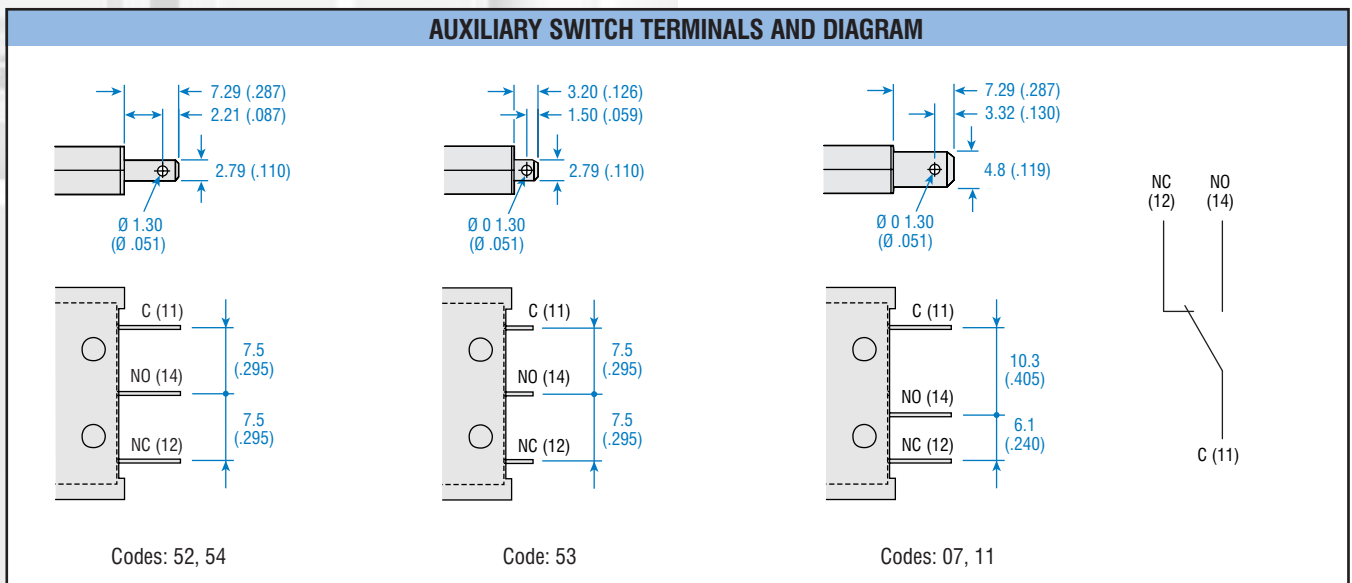

① Terminal length tol. ± 1,6 (.062)

APPROXIMATE IN MM (INCHES)

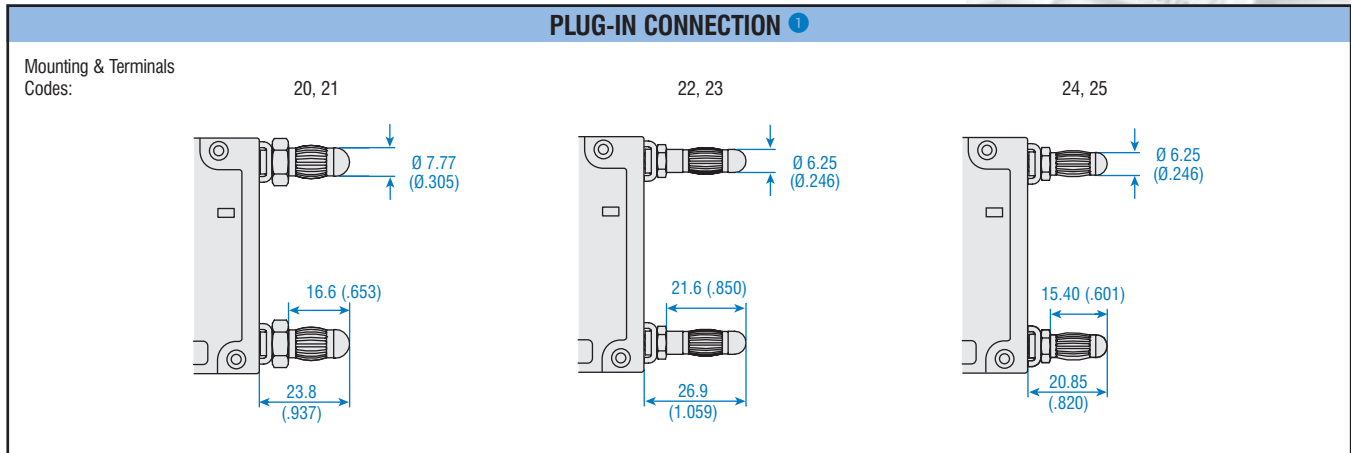

1 Mating holes for codes 20, 21  $\varnothing$  7.90 (.311) - For codes 22, 23, 24 and 25  $\varnothing$  6.35 (.250).

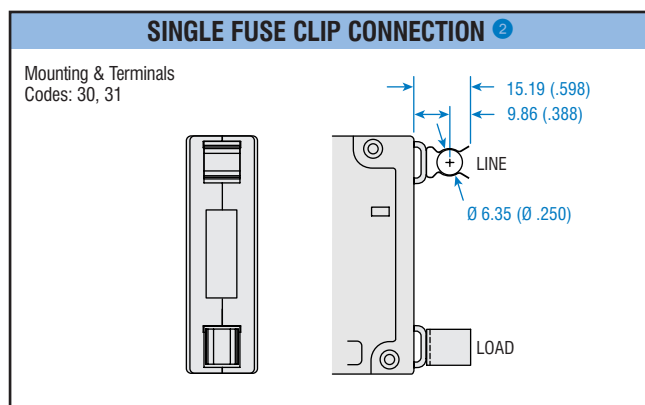
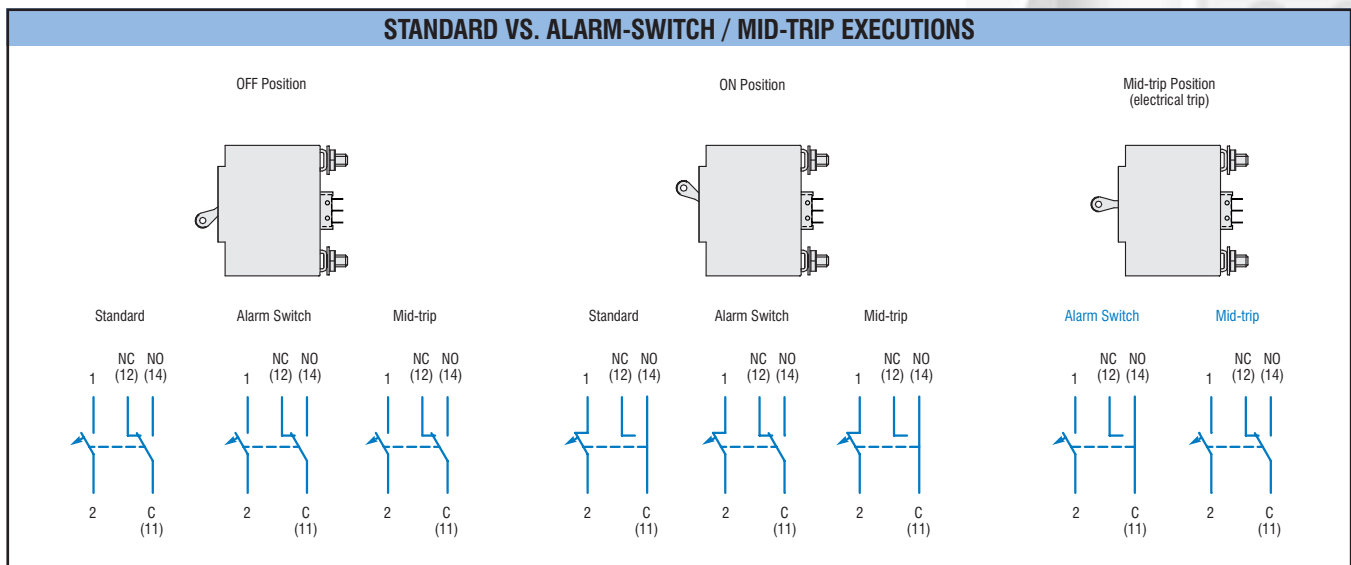

2 Not available with AM1P series, 200 A version.

# HEINEMANN® AM/R AND AM1P SERIES CIRCUIT BREAKERS

## Series AM/R (up to 100 A)

### HOW TO ORDER

To determine your **Complete Catalog Number**, start with **Series Prefix AM** and add the appropriate **Code Letters** and/or **Numbers** as in the example below. Any part number with greater than 26 digits including dashes will be shipped with a factory-assigned part number.

Step 1	Step 2	Step 3	Steps 4				Step 5	Step 6	Step 7	
Series Prefix	Poles ①	Series Suffix	Frequency	Internal Circuit ②				Handle Location	Handle Color & Marking	Mounting & Terminals ③
AM	2	R-	A	9				- L	C	15

### SELECTION TABLE

Series Prefix	Poles ①	Series Suffix	Frequency		Internal Circuit ②				Handle Location		Handle Color & Marking		Mounting & Terminals ③		
			Frequency	Code	Inrush Code	Aux. Switch	Description	Code	Handle	Code	Color & Marking	Code	Mounting	Terminals	Code
AM	1	R-	50/60 Hz	A	-	No	Switch Only	0		- A	Black ON/OFF	A	6-32	10-32 Threads 70 A	07
					8 X	Yes	Series Trip	2		- B	White ON/OFF	B	6-32	1/4-20 Threads 100 A	97
					8 X	No	Series Trip	3		- B	White ON/OFF	B	M3-0.5	10-32 Threads 70 A	13
					8 X	No	Shunt-Tap	5		- C	Black I/O ON/OFF	C	M3-0.5	1/4-20 Threads	14
					8 X	No	Relay Trip	6		- C	Black I/O ON/OFF	C	M3-0.5	M5 Threads 70 A	15
					8 X	No	Dual Rating	7		- C	Black I/O ON/OFF	C	M3-0.5	M6 Threads	16
					18 X	No	Series Trip	8		- L	White I/O	L	M3-0.5	Gold Plug-In Ø 7.77 x 16.6	20
					18 X	Yes	Series Trip	9		- L	White I/O	L	M3-0.5	Gold Plug-In Ø 7.77 x 16.6	21
					-	Yes	Switch Only	12		- D	White I/O ON/OFF	D	M3-0.5	Silver Plug-In Ø 6.25 x 21.6	22
					8 X	No	DuCon ④	15		- M	Orange I/O ON/OFF	M	6-32	Silver Plug-In Ø 6.25 x 21.6	23
					8 X	No	DuCon ④	16		- M	Orange I/O ON/OFF	M	6-32	Silver Plug-In Ø 6.25 x 21.6	23
					18 X	No	Series + Relay	22		- N	Gray I/O ON/OFF	N	M3-0.5	Silver Plug-In Ø 6.25 x 15.4	24
					18 X	No	Shunt-Tap	23		- P	Yellow I/O ON/OFF	P	6-32	Silver Plug-In Ø 6.25 x 15.4	25
					18 X	No	DuCon ④	25		- L	Black Without	L	M3-0.5	Double Fuse Clip ⑤	27
					18 X	No	DuCon ④	26		- L	Black Without	L	6-32	Double Fuse Clip ⑤	29
					18 X	No	Dual Rating	27		- R	White Without	R	M3-0.5	Fuse Clip ⑥	30
					25 X	No	Shunt-Tap	32		- P	Red I/O ON/OFF	P	M3-0.5	Fuse Clip ⑥	31
					25 X	No	Relay Trip	33		- S	Blue I/O ON/OFF	S	M3-0.5	10-32 Threads 50 A	41
					25 X	No	Series Trip	38		- S	Blue I/O ON/OFF	S	M3-0.5	M6 Screw	42
					25 X	Yes	Series Trip	39		- X	Blue I/O ON/OFF	X	M3-0.5	1/4-20 Screw	43
					18 X	No	Relay Coil	76		- Y	Green I/O ON/OFF	Y	6-32	10-32 Threads 50 A	45
					25 X	No	Mid-Trip Series Shunt	78		- L	Green I/O ON/OFF	L	6-32	M6 Screw	46
					25 X	Yes	Mid-Trip Shunt Alarm	79		- L	Green I/O ON/OFF	L	6-32	1/4-20 Screw	47
					8 X	No	Relay Coil	86							
					25 X	No	Relay Coil	96							
					8 X	No	Mid-Trip	98							
					8 X	No	Mid-Trip with Alarm Switch	99							

① Configurations greater than 4 poles must be "without" UL in Step 8.

② Other circuits available. Please contact Customer Service Center.

③ DuCon Internal Circuits are only available with 1 pole versions, 0.01A-50A. For DuCon configurations requiring above 50A or 2 or more poles, please contact Customer Service Center.

④ Other mounting and terminal configurations available. Please contact Customer Service Center.

⑤ 100 A max for UL Approval. VDE Pending.

⑥ 50 A max for UL-Approval. VDE Pending.

Complete Part Number: AM2R-A9-LC15D-A52-12R5-4

Step 8	Step 9	Step 10 ⑨ ⑩	Step 11 ⑪	Step 12
Worldwide Approvals	UL-AIC Approval	Auxiliary Switch	Current Ratings	Time Delay Curves
D-	A	52	-12R5	- 4

Worldwide Approval		UL-AIC Approval ⑧						Auxiliary Switch ⑨ ⑩						Current Ratings ⑪	Time Delay Curves					
Description	Code	UL Std A	Max. Ratings	Max. V	Freq.	Interrupt Cap.	Code	Function	Contacts	Terminals	UL/CSA	VDE	Volt AC	Code	Ampere	Inrush Level	Time Delay	Frequency	Code	
Without (Standard) VDE & CE in conf. with IEC 950 Meets IEC 950 electrical spacing requirements TUV approved and CE marked	D-	UL 1077	100 A	240 V 250 V 80 V	50/60 Hz 400 Hz DC	5K IAC	A										8 X	Long	50/60 Hz DC 400 Hz 50/60 Hz DC	- 1
		Without	100 A	240 V 250 V 80 V	50/60 Hz 400 Hz DC	5K IAC	NU										8 X	Medium	50/60 Hz DC 400 Hz 50/60 Hz DC	- 2
		UL 1077	50 A	277 V	50/60 Hz	5K IAC	L										8 X	Short	50/60 Hz DC 400 Hz 50/60 Hz DC	- 3
	H- ⑦	Without	50 A	415 V	50/60 Hz	5K IAC	AD ⑧	NO-NC	Ag	2.8 Fast-on	10.1 A	-	220	06	From	18 X	Long	50/60 Hz DC 50/60 Hz DC	- 4	
		UL 1077	30 A	480 V	50/60 Hz	5K IAC	AB ⑧	NO-NC	Ag	4.8 Fast-on	10.1 A	-	220	07	R02	18 X	Medium	50/60 Hz DC 50/60 Hz DC	- 5	
		Without	30 A	480 V	50/60 Hz	5K IAC	NB ⑧	NO-NC	AgAuPt	4.8 Fast-on	0.1 A	-	125	11	to	18 X	Medium	50/60 Hz DC 50/60 Hz DC	- 6	
	W-	UL 489	20 A	120/ 240 V	50/60 Hz	10K IAC	DK	NO-NC	Ag	2.8 Fast-on	10.1 A	1.0 A	220	52	100	18 X	Short	50/60 Hz DC 50/60 Hz DC	- 6	
		UL 489	80 A	80 V	DC	50 K @ 65 VDC	DL	NO-NC	AgAuPt	2.8 Fast-on	0.1 A	0.1 A	220	54	Amps	25 X	Long	50/60 Hz DC	- 7	
		UL 489 A	100 A	80 V	DC	50 K @ 65 VDC	AJ									25 X	Medium	50/60 Hz DC	- 8	
	T-	UL 489	50A 100 A	120/ 240 V 80 V	50/60 Hz DC	5K IAC 5K IAC	DU										-	Instant	50/60 Hz DC 400 Hz	- P
		UL 489A	100 A	80 V	DC	5K IAC	AU										-	Switch only	50/60 Hz DC 400Hz	- S
		UL 1077	50 A	125 V	DC	5K IAC	C										-	Customer specified	50/60 Hz DC 400 Hz	- T
	Without	50 A	125 V	DC	5K IAC	NC														

⑦ VDE approval pending. Applicable only with Internal Circuits Codes: 0, 2, 3, 5, 8, 9, 12, 15, 16, 22, 25, 26, 32, 38, 39 and 86.

⑧ AD code is only available with a 2-pole execution minimum and AB available only with a 3-pole execution minimum.

⑨ Other auxiliary switches available. Please contact Customer Service Center.

⑩ Step 10 is only required if breaker has auxiliary switch. If auxiliary switch is not required, omit Step 10.

⑪ All ratings between .02 A and 100 A are available. A value less than 1 A requires the character "R" in place of the decimal point. For example, 2.5 A would be specified as 2R5.

# HEINEMANN® AM1P SERIES CIRCUIT BREAKERS

## Series AM1P (101 to 200 A)

### HOW TO ORDER

To determine your **Complete Catalog Number**, start with **Series Prefix AM** and add the appropriate **Code Letters** and/or **Numbers** as in the example below. Any part number with greater than 26 digits including dashes will be shipped with a factory-assigned part number.

Step 1	Step 2	Step 3	Step 4				Step 5	Step 6	Step 7	
Series Prefix	Poles ①	Series Suffix	Frequency	Internal Circuit ②				Handle Location	Handle Color & Marking	Mounting & Terminals
AM	1	P-	B	9				- L	C	14

### SELECTION TABLE

Series Prefix	Poles	Series Suffix	Frequency		Internal Circuit ②				Handle Location		Handle Color & Marking		Mounting & Terminals						
			Frequency	Code	Inrush Code	Aux. Switch	Description	Code	Handle	Code	Color & Marking	Code	Mounting	Terminals	Code				
AM	1	P-	DC	B	8 X	Yes	Series Trip	2		- B	Black ON/OFF	A	6-32	1/4-20 Threads 100 A	97				
						No	Series Trip	3			White ON/OFF	B							
						No	Shunt-Tap	5			Black I/O ON/OFF	C				6-32	M6 Threads 100 A	98	
						No	Series Trip	8			White I/O	J				M3-0.5	1/4-20 Threads 100 A	14	
						Yes	Series Trip	9			White I/O ON/OFF	K				M3-0.5	M6 Threads 100 A	16	
						No	DuCon	15			M3-0.5	Plug-In Ø 7.77 x 16.6				20			
						No	DuCon Series+Relay	16 ③			- L	Orange I/O ON/OFF				M	6-32	Plug-In Ø 7.77 x 16.6	21
						No	Shunt-Tap	22			M3-0.5	Plug-In Ø 6.25 x 21.6				22			
						No	Relay Trip	23			- D	Gray I/O ON/OFF				P	6-32	Plug-In Ø 6.25 x 21.6	23
						No	DuCon Series+Relay	26 ③			- M	Yellow I/O ON/OFF				Q	M3-0.5	Plug-In Ø 6.25 x 15.4	24
						No	Dual Rating	27			6-32	Plug-In Ø 6.25 x 15.4				25			
						No	Shunt-Tap	32			M3-0.5	M6 Screw				42			
						No	Series Trip	38			- N	Black Without				R	M3-0.5	1/4-20 Screw	43
						Yes	Series Trip	39			6-32	M6 Screw				46			
						No	Mid-Trip	98			- L	White Without				S	6-32	1/4-20 Screw	47
						No	Mid-Trip with Alarm switch	99			Red I/O ON/OFF	T				Blue I/O ON/OFF	X	Green I/O ON/OFF	Y

① For the AM1P series, the part number will always denote "1" as the number of poles in Step 2. However, the number of poles actually received are based on the current rating selected in Step 11. If you order a 100-150A breaker, you will receive a 2 pole breaker and, if you order a 151-200A breaker, you will receive a 3 pole breaker.

② Other circuits available. Please contact Customer Service Center.

③ For Internal Circuit codes 16 and 26 please select "Without UL" – code NU in Step 9.



Complete Part Number: AM1P-B9-LC14D-AU52-101-4

Step 8	Step 9	Step 10	Step 11	Step 12
Worldwide Approvals	UL-AIC Approval	Auxiliary Switch ④ ⑤	Current Ratings ⑥	Time Delay Curves
D –	AU	52	–101	– 4

Worldwide Approval		UL-AIC Approval						Auxiliary Switch ④ ⑤						Current Ratings	Time Delay Curves					
Description	Code	UL Std.	Max. Ratings	Max. V	Freq.	Interrupt Cap.	Code	Function	Contacts	Terminals	UL/ CSA	VDE	Volt AC	Code	Ampere ⑥	Inrush Level	Time Delay	Frequency	Code	
Without (Standard)	D –	Without	101-200	65 V	DC	50K	NU	NO-NC	Ag	4.8 Fast-on	10.1 A	–	220	07	From – 101 to – 200 Amps	8 X	Long	DC	– 1	
		UL 489 A	101-200	65 V	DC	50K	GU	NO-NC	AgAuPt	4.8 Fast-on	0.1 A	–	125	11		8 X	Medium	DC	– 2	
		UL 489 A	101-200	80 V	DC	10K	AU	NO-NC	Ag	2.8 Fast-on	10.1 A	1.0 A	220	52		8 X	Short	DC	– 3	
									NO-NC	Ag	to be weld	10.1 A	1.0 A	220		53	18 X	Long	DC	– 4
									NO-NC	AgAuPt	2.8 Fast-on	0.1 A	0.1 A	220		54	18 X	Medium	DC	– 5
																	18 X	Short	DC	– 6
																	25 X	Long	DC	– 7
																	25 X	Medium	DC	– 8
																	25 X	Short	DC	– 9
																	–	Instant	DC	– P ⑦

④ Step 10 is only required if breaker has auxiliary switch. If auxiliary switch is not required, omit Step 10.

⑤ Other auxiliary switches available. Please contact Customer Service Center.

⑥ All ratings between 101 and 200 A are available. Consult Customer Service Center for availability and delivery time. A value less than 1 A requires the character "R" in place of the decimal point when ordering. For example, 125.5 A would be specified as 125R5 in the part number.

⑦ No deliberate time delay imposed.

# HEINEMANN® CIRCUIT BREAKERS

**For the Widest Selection of Circuit Protection, from 0.01 to 1200 Amperes, Look to Eaton's Heinemann Brand Products.**

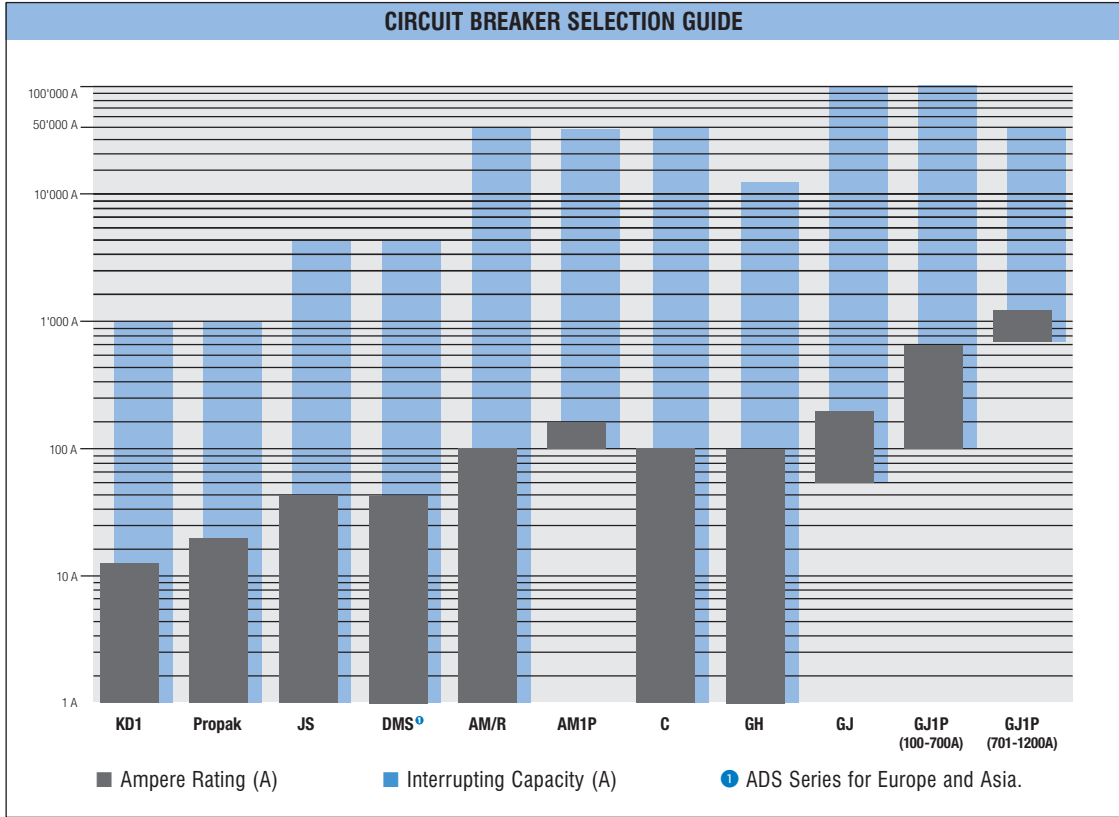

Eaton Corporation  
**Cutler-Hammer Group**  
**Molded Case Business Unit**  
 4201 N. 27<sup>th</sup> Street  
 Milwaukee, WI 53216

**Americas Customer Service**  
 Phone: (800) 962-0820; Phone: (414) 449-6207  
 Fax: (414) 449-6118  
[www.commercialcontrols.eaton.com](http://www.commercialcontrols.eaton.com)

Eaton SA  
**Cutler-Hammer Group**  
**Molded Case Business Unit**  
 CH-1345 Le Lieu, Switzerland  
 Tel: + 41 21 841 9211; Fax: + 41 21 841 9200

**Europe and Far East Customer Service**  
 Tel: + 41 21 841 9211; Fax: + 41 21 841 9200

**EATON**

**Heinemann**

© 2001 Eaton Corporation  
 All Rights Reserved  
 Printed in USA  
 Publication BR5401SE0005A  
 December 2001