

1 2 3 4 5 6 7 8

REVISIONS		
ISS	ZONE	DESCRIPTION\PER REQUEST\DATE

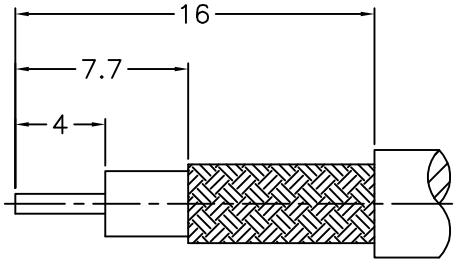

RECOMMENDED
CABLE STRIPPING DIM'S
(建議剝線尺寸)

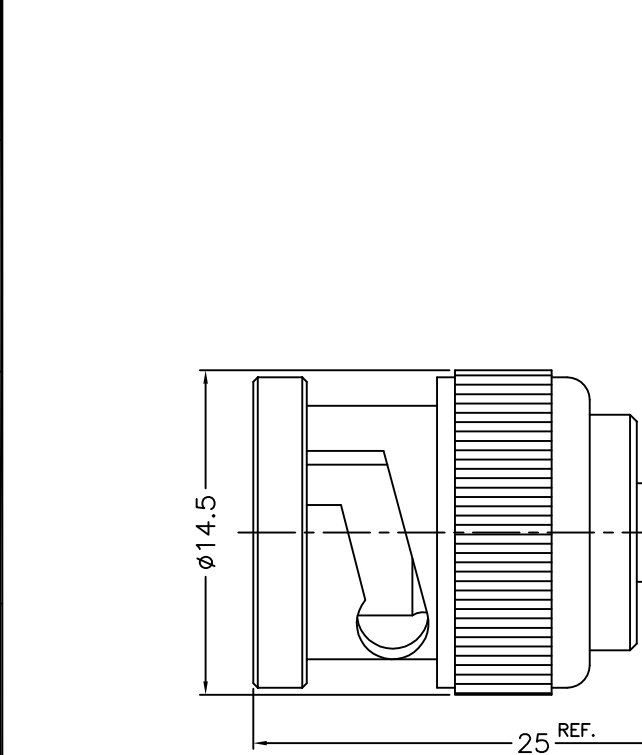
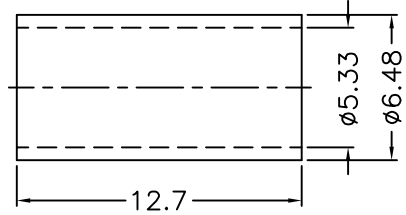
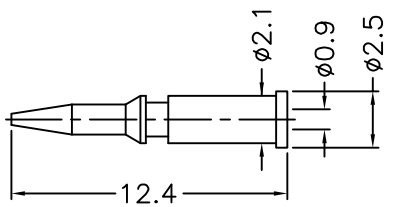

NOTES: FINISH (PLATING THICKNESS IN MICRO-INCHES)
 1. BRASS
 2. NICKEL PL. 100 MIN. THICK OVER COPPER PL. 50 MIN. THICK
 3. GOLD PL. 3 MIN. THICK OVER NICKEL PL. 50 MIN. THICK OVER COPPER PL. 50 MIN. THICK
 4. TEFLON

1. CRIMPED FERRULE
HEX CRIMP SIZE .213"
 2. CRIMPED CONTACT PIN
HEX CRIMP SIZE .068"

9	FERRULE	COPPER	NOTE 2	1	FR-533-648 -127C
8	CONTACT PIN	NOTE 1	NOTE 3	1	900-1121A1-8 -0.9
7	WASHER	NOTE 1	NOTE 2	1	WS-90-128-08
6	SPRING	SK5	NOTE 2	1	900-1000-6
5	RETAINER RING	NOTE 1	NOTE 2	1	900-1000-5
4	GASKET	RUBBER	RED	1	GS-80-115-15
3	INSULATOR	NOTE 4	NATURAL	1	900-1000-3-50T
2	BODY	NOTE 1	NOTE 2	1	900-1000-2-06
1	SHELL	NOTE 1	NOTE 2	1	900-1000-1
NO.	DESCRIPTION	MATERIAL	FINISH	Q'TY	DRAWING NO.

DIMENSIONS ARE IN MILLIMETERS			PART NO.	
UNLESS OTHERWISE SPECIFIED TOLERANCES			APPROVED	
0.5-6 = ±0.2	6-30 = ±0.4		DATE	04-17-'13
30-120 = ±0.6	120-315 = ±1		CHECKED	DATE
315-1000 = ±1.6	1000-2000 = ±2.4		DRAWN	DATE
SCALE	3/1	ISSUE	04-17-'13	

G.L.I.	
TITLE BNC CRIMP PLUG (FOR RG-58, 58A, 141, LMR195)	
DRAWING NO. 900-1121A1-06-50	
FILE NO. R:\D\G\DWG\900\1121A1\06\50	

1 2 3 4 5 6 7 8