

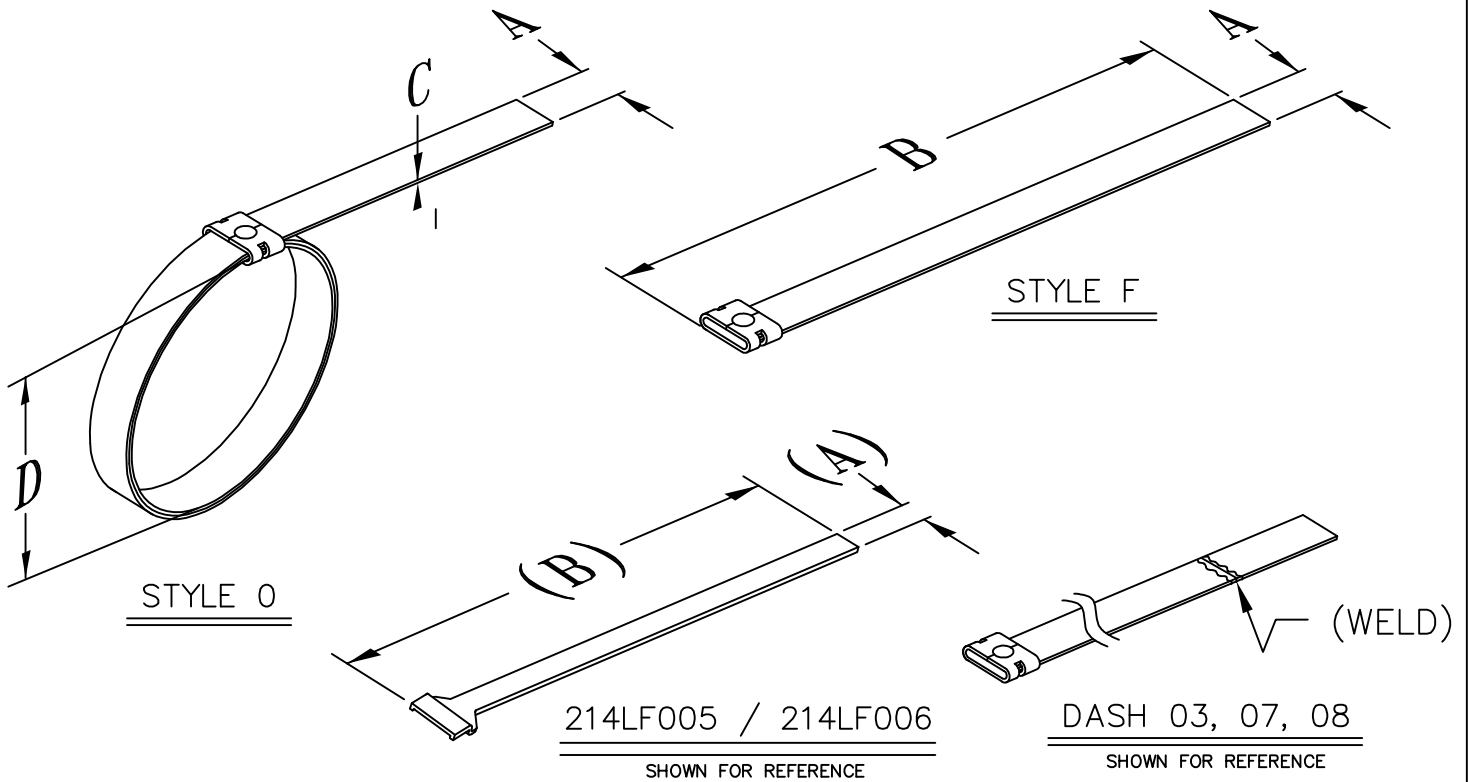

ELECTRO ADAPTER INC.
 CHATSWORTH, CALIFORNIA, USA 91311
 PHONE (818) 998-1198
 FAX (818) 709-5773

**SECTION 2 - BANDING TERMINATION
 WIRE HARNESS ACCESSORIES,
 ELECTRICAL, EMI / RFI / EMP,
 SHIELD TERMINATION BAND,
 PER AS85049 CATEGORY 7**

214L
 SHEET 1 OF 1



Example Part Number

214LF002

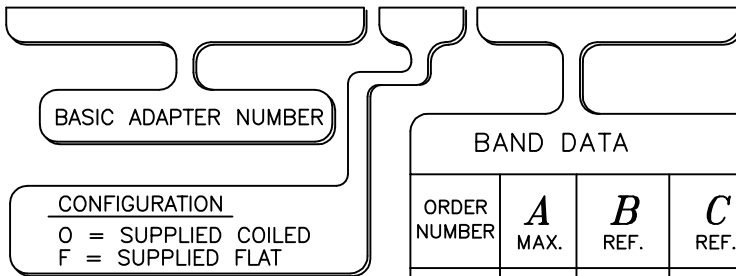

ORDER NUMBER	A MAX.	B REF.	C REF.	ØD APPROX.		REF INSTALLATION TOOL
				FULL OPEN	MIN. INSTALLED	
002	.255	12.00	.019	1.50	.156	2 STEP
003	.255	15.00	.019	1.50	.156	2 STEP
005	.128	8.125	.015	.88	.125	1 STEP
006	.255	14.25	.019	1.80	.156	1 STEP
007	.255	18.00	.019	2.50	.156	1 STEP
008	.255	14.00	.019	1.80	.156	2 STEP

NOTES: UNLESS OTHERWISE SPECIFIED

- ASSEMBLY IDENT. PER MIL-STD-1285
- MATERIAL: 300 SERIES STAINLESS STEEL
- FINISH: PASSIVATE PER SAE AMS2700D
- BANDS MUST BE DOUBLE WRAPPED.
- INSTALL USING EAI TOOL EAT214-25
- INSTALL USING BAND-IT[®] TOOL #A30199
- INSTALL USING BAND-IT[®] TOOL #A40199
- BAND(S) COME BAGGED AND TAG IN QTY(S) FROM 1 TO 100
- BAND(S) MEET REQUIREMENTS OF M85049/128

QUALIFIED 21 MARCH 2019 SAE AS85049/128 CROSS REFERENCE	
MFR DESIGNATION	SPEC DESIGNATION
214LF008	M85049/128-1
214L0008	M85049/128-2
214LF006	M85049/128-3
214L0006	M85049/128-4
214LF005	M85049/128-7
214L0005	M85049/128-8

BAND P/N	For Entry Orde No	Cable Entry Size (inch/mm)
214LF005	02 - 12	0.125"/3.175 mm - 0.750"/19.05 mm
214LF006	02 - 24	0.125"/3.175 mm - 1.50"/38.1 mm