

# AS85049/60-2G and MS3416-G

## Shrink Boot Adapters

MIL-DTL-5015 Series 3400,  
MIL-DTL-26482 Series 2,  
AS81703 Series 3,  
MIL-DTL-83723 Series I &  
III, 40M39569, DEF 5326-3,  
EN 2997, EN 3646,  
ESC 10, ESC 11, LN 29504,  
NFC93422 Series HE302,  
PAN 6432-1, PAN 6432-2,  
PATT 602

### M85049/60-2G 22 W

Basic Part No. \_\_\_\_\_  
Shell Size \_\_\_\_\_

Finish  
A = Anodize Black  
N = Electroless Nickel  
W = 1,000 Hr. Cadmium Olive Drab  
Over Electroless Nickel

### MS3416-22 G C

Basic Part No. \_\_\_\_\_  
Shell Size \_\_\_\_\_  
Style \_\_\_\_\_

### Superceded Part Number

Finish  
C = Cadmium Olive Drab Over  
Electroless Nickel  
N = Electroless Nickel

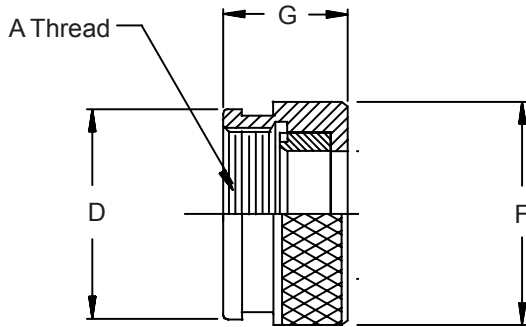

1. For complete dimensions see applicable Military Specification.
2. Metric dimensions (mm) are indicated in parentheses.

**TABLE I**

Shell Size	A Thread Class 2B	D Dia		F Dia		G Max
		+ .000 (0.0)	- .020 (0.5)	+ .000 (0.0)	- .045 (1.1)	
3	.562 - 24 UNEF	.709	(18.0)	.750	(19.1)	.540 (13.7)
8	.500 - 20 UNF	.657	(16.7)	.688	(17.5)	.540 (13.7)
10	.625 - 24 UNEF	.774	(19.7)	.803	(20.4)	.540 (13.7)
12	.750 - 20 UNEF	.898	(22.8)	.938	(23.8)	.540 (13.7)
14	.875 - 20 UNEF	1.024	(26.0)	1.063	(27.0)	.540 (13.7)
16	1.000 - 20 UNEF	1.152	(29.3)	1.238	(31.4)	.540 (13.7)
18	1.062 - 18 UNEF	1.243	(31.6)	1.310	(33.3)	.540 (13.7)
20	1.188 - 18 UNEF	1.370	(34.8)	1.436	(36.5)	.540 (13.7)
22	1.313 - 18 UNEF	1.443	(36.7)	1.560	(39.6)	.540 (13.7)
24	1.438 - 18 UNEF	1.618	(41.1)	1.686	(42.8)	.540 (13.7)
28	1.750 - 18 UNS	1.969	(50.0)	2.062	(52.4)	.702 (17.8)
32	2.000 - 18 UNS	2.219	(56.4)	2.312	(58.7)	.702 (17.8)
36	2.250 - 16 UN	2.469	(62.7)	2.562	(65.1)	.702 (17.8)
40	2.500 - 16 UN	2.719	(69.1)	2.812	(71.4)	.702 (17.8)
44	2.750 - 16 UN	2.969	(75.4)	3.062	(77.8)	.702 (17.8)
48	3.000 - 16 UN	3.219	(81.8)	3.312	(84.1)	.702 (17.8)
61	1.500 - 18 UNEF	1.653	(42.0)	1.748	(44.4)	.540 (13.7)