

X13 Series – 13mm Laser Trackball, Panel Mount, Protocol Output

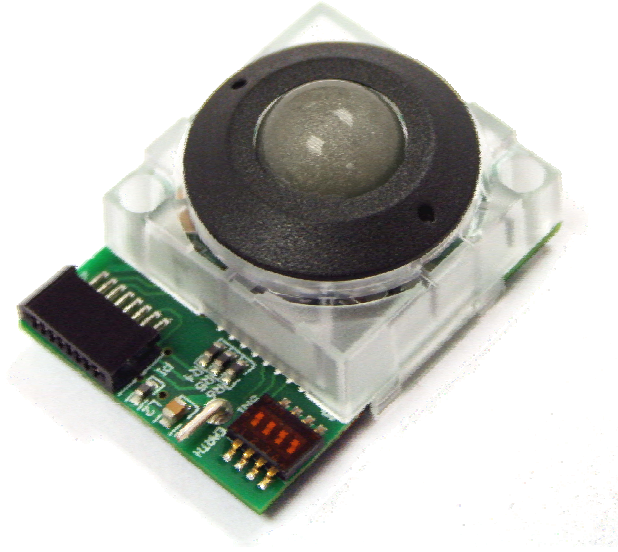

1. DESCRIPTION

Utilizing the latest and most advanced laser tracking technology, the X13 series laser Trackerball™ is an extremely high specification, contact-less device, ideal for the most demanding of cursor control applications.

The laser tracking engine provides accurate cursor motion at all speeds and on virtually any ball, combining the benefits of solid state sensing (no moving parts except the ball) with the aesthetics, functionality and performance associated with the Cursor Controls product range.

The design incorporates a removable top ring as standard to allow for easy cleaning, decontamination, sterilisation and maintenance - ensuring continued optimum performance and operation under the harshest of conditions.

The X13 series trackballs are available with a variety of electrical outputs, tracking force options, and sealing capabilities up to IP68.

The trackball has been designed to be back of panel mounted as part of OEM keyboards and consoles

2. FEATURES

- Solid state sensing technology – laser tracking engine
- Sealing up to IP68
- Output: USB/PS2 (auto-select) or SUN Systems
- Smooth operation in rugged environments
- Various top plate configurations
- Custom connector options
- Various ball colours

3. APPLICATIONS

- Medical systems
- Marine systems
- Custom keyboard applications
- Industrial consoles
- OEM custom solutions available

4. SPECIFICATIONS
4.1 Mechanical

Weight	~15 grams
Ball	Ø12.7mm (0.5")
Ball material	Phenolic, polyester, epoxy resin
Tracking force	10 grams nominal – damper ring (see section 8 for ordering code details)
	10-30 grams – Silicone rubber seal (see section 8 for ordering code details)
Ball load	50N (5Kg) maximum downward pressure for 2 minutes @20°C
Resolvable ball speed	40 IPS (inches per second)
Mounting position	All angles
Tracking engine	Laser navigation technology - solid state sensing
Top plate material	PC/ABS - Black
Sealing gasket	Silicone seal (DC7091 black)

4.2 Electrical

Protocol	USB, PS/2 (auto-select) or SUN Systems (see section 8 for ordering code details)
Supply voltage	4.4V to 5.25V D.C.
Supply current	23mA typical, 25mA maximum
Resolution	300 counts per ball revolution @ 1 IPS (inches per second) +/- 10% 600 counts per ball revolution @ 5 IPS (inches per second) +/- 10%
Output connector	8 Way, right-angled JST film connector, part no: 08FM-1.0SP-1.9-TF
Mating output connector	Flexible flat cable (FFC), 1.0mm pitch
Laser safety class	Embedded class 1M laser safety, IEC 60825-1

4.3 Environmental

Operating temperature	0°C to +55°C (IEC 60068-2-1, IEC60068-2-2)
Storage temperature	-40°C to + 85 °C (IEC 60068-2-1, IEC60068-2-2)
Operating humidity	93% RH @ 40°C, non-condensing (IEC 60068-2-78)
Storage humidity	10%-95% non-condensing (IEC 60068-2-78)
Vibration	5g, 10-500Hz, 1 octave/min, 10 sweep cycles (IEC 60068-2-6)
Operating Shock	15g/11ms, ½ sine, 3 shocks in +ve and -ve direction, all 3 axes (IEC 60068-2-27)
Mechanical lifetime	1 million ball revolutions
MTBF	in excess of 80,000 hours (MIL-STD-217F)
ESD	15kV air-discharge and 8kV contact discharge (IEC 61000-4-2)
EMC	Radiated immunity - limits according to level 3 of IEC 61000-4-3
	Radiated emissions to EN55022 class B
Sealing capability	IP68 (BS EN 60529)

4.4 Electrical Compatibility

The X13 Series trackball has been tested for compatibility with the following operating systems;

Windows 95
Windows 98
Windows 2000
Windows ME
Windows NT4
Windows XP
Windows Vista
Redhat Linux
Fully compliant with USB 1.1 framework (chapter 9) and HID specifications

5. CONNECTION DETAILS

Connection is made to the X13 Series trackball by means of a single 8-way, right-angled, JST film connector (or equivalent). Table 1 highlights the connection details. Custom connections are available (please contact your local sales office for further details).

5.1 Output Connector: P1

Description: header 8 way FM 1.0mm pitch
 Manufacturer: JST (or equivalent)
 Part No: 08FM-1.0SP-1.9-TF
 Mating connector: Flexible flat cable (FFC), 1.0mm pitch

Pin Number	USB/PS/2	SUN Systems
1	+5V DC	+5V DC
2	D-, PS/2 Data	Data
3	D+, PS/2 Clock	Do not connect
4	Right Switch	Right Switch
5	Left Switch	Left Switch
6	0V	0V
7	Middle Switch	Middle Switch
8	N.C.	N.C.

Table 1 Output connections

6. TRACKBALL CONFIGURATION

The X13 Series trackball provides features that may be selected using the DIP switch located on the printed circuit board. Table 2 details the assigned function of each switch.

6.1 DIP Switch Functions

DIP Switch	Function	OFF	ON
1	Orientation 1 Setting	See Figure.1	See Figure.1
2	Orientation 2 Setting	See Figure.1	See Figure.1
3	Not used	N/A	N/A
4	Not used	N/A	N/A

Table 2 DIP switch functions

Factory default setting: All DIP switches OFF

6.2 Orientation

The orientation function allows the user to mount the X13 Series trackball device in one of four positions (see figure. 1 below). The orientation of the device is determined by the direction in which the output connector is facing (when viewed from the top of Trackerball device). The Tracker ball orientation can be selected to accommodate customer requirements for connector location and wiring.

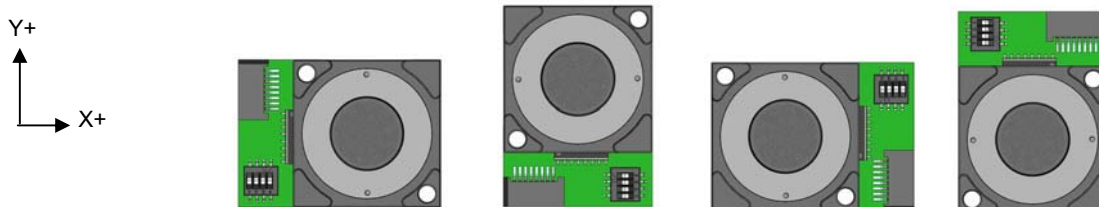

Switch 1(Orientation 1)	OFF	ON	OFF	ON
Switch 2 (Orientation 2)	OFF	OFF	ON	ON

Figure 1 Mounting Orientations

7. DIMENSION DRAWING

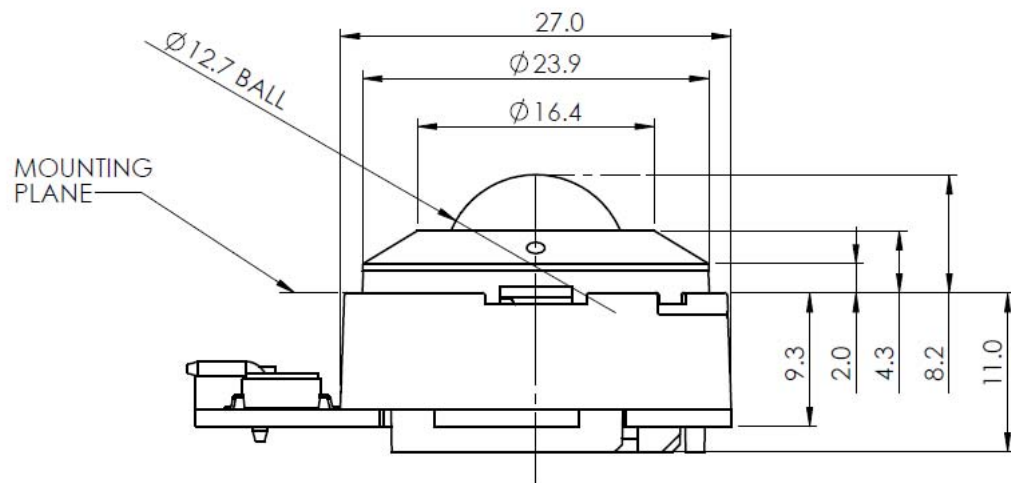
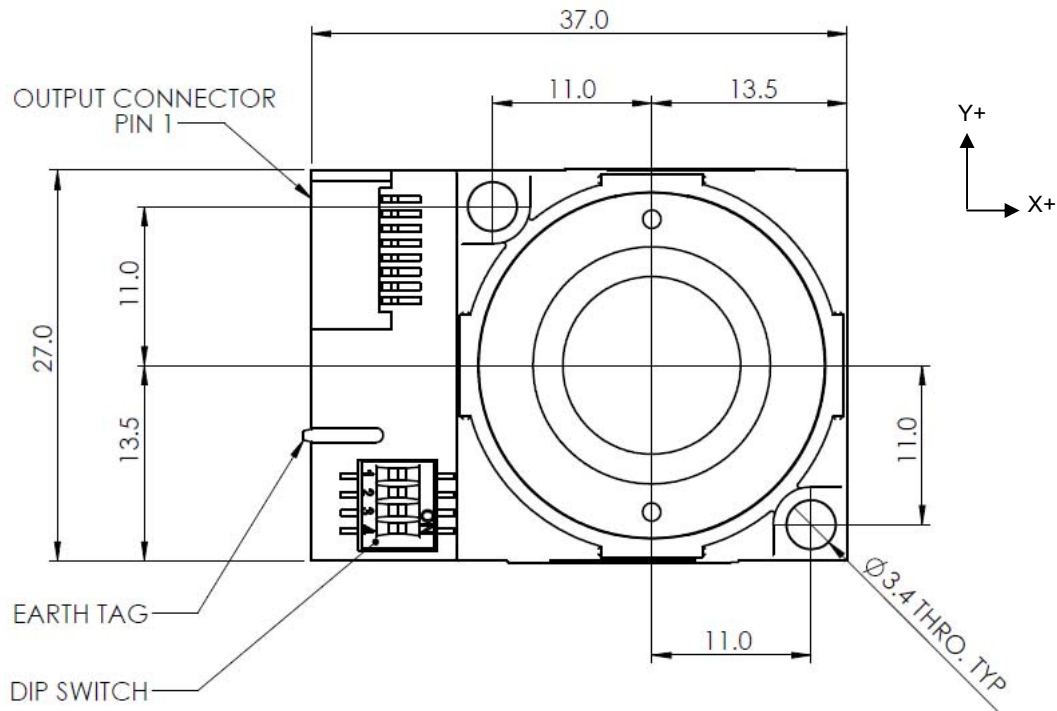

Dimensional drawing specifies factory default orientation.

All dimensions are in mm unless otherwise stated.

Tolerances +/- 0.2mm unless otherwise stated

Please note that an IGES model is available on request. Please contact your local sales office for more information.

8. PRODUCT ORDERING CODE SYSTEM

Please construct your standard product ordering code by selecting the numbers and letters to suit your specification:

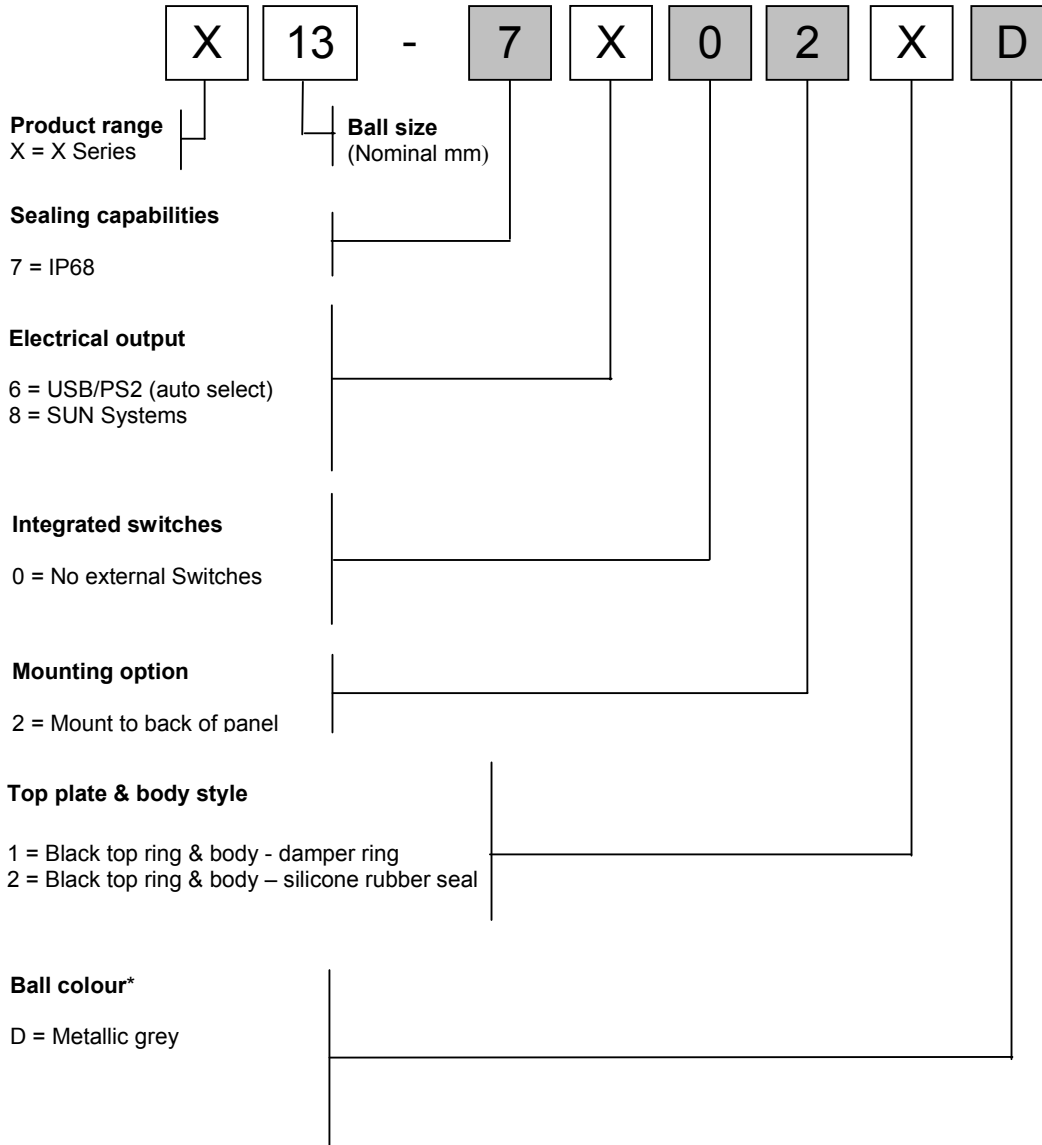

*For further options on ball colours please contact your local sales representative

8.1 Ordering Example

X13-76021D: X13, IP68, USB/PS/2, no switches, mount to back of panel, black top ring - damper ring, metallic grey ball.

9. DOCUMENT HISTORY

Issue	Date	Author	Remarks
A	05.11.09	SdB	Document released

Whilst the information provided herein is to the best of our knowledge true and accurate, it should be used for guidance only and may be subject to change. You are therefore advised to ensure all information provided herein is current and up to date and suitable for your application. Use of Cursor Controls Ltd products in life support systems is only permitted with prior written consent of the Company.