

REV.  
B

SAE AS85049/88

FEDERAL SUPPLY CLASS  
5935

RATIONALE

REVISED TO INCLUDE COMMENTS RECEIVED BY THE GOVERNMENT / INDUSTRY AND INCORPORATED THE AS85049/88A-A1 AMENDMENT. ALIGN SPECIFICATION WITH SAE GUIDELINES AND REVIEWED SPECIFICATION FOR KNOWN TECHNICAL ISSUES.

NOTICE

THE REQUIREMENTS FOR PROCURING THE PRODUCT DESCRIBED HEREIN SHALL CONSIST OF THIS SPECIFICATION SHEET AND THE ISSUE OF SAE AS85049.

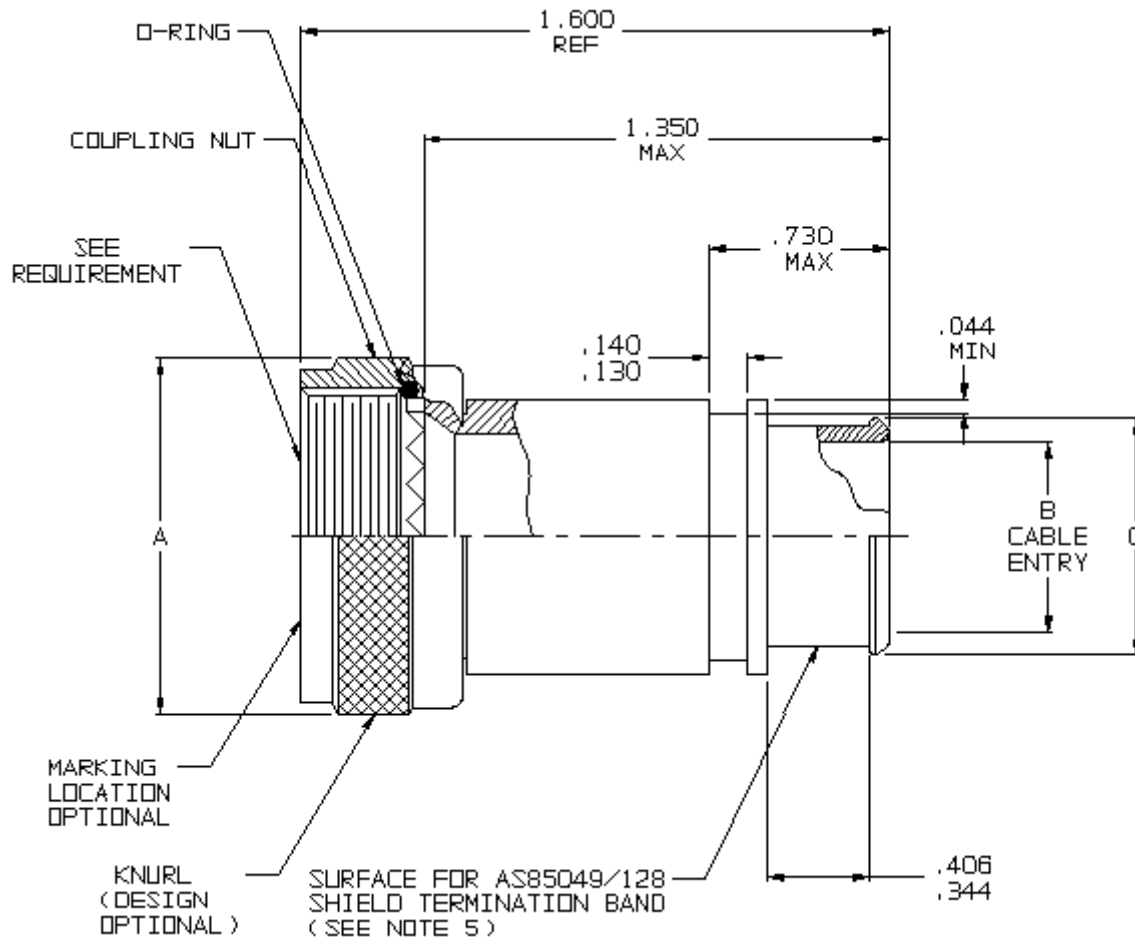
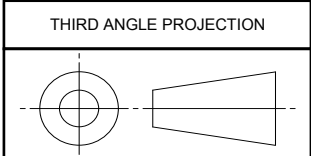

FIGURE 1 - CONFIGURATION AND DIMENSIONS

SAE values your input. To provide feedback on this Technical Report, please visit <http://www.sae.org/technical/standards/AS85049/88B>



SAE Technical Standards Board Rules provide that: "This report is published by SAE to advance the state of technical and engineering sciences. The use of this report is entirely voluntary, and its applicability and suitability for any particular use, including any patent infringement arising therefrom, is the sole responsibility of the user." SAE reviews each technical report at least every five years at which time it may be reaffirmed, revised, or cancelled. SAE invites your written comments and suggestions.

ISSUED 2000-06 REVISED 2011-01

CUSTODIAN: AE-8/AE-8C1		PROCUREMENT SPECIFICATION: AS85049	
	<b>AEROSPACE STANDARD</b>		<b>SAE AS85049/88</b> SHEET 1 OF 4
	(R) CONNECTOR ACCESSORIES, ELECTRICAL, BACKSHELL, STRAIGHT, SELF-LOCKING, SHIELD BAND TERMINATION (RFI/EMI), SHRINK BOOT ACCOMMODATION, CATEGORY 3B (FOR MIL-DTL-38999 SERIES III AND IV CONNECTORS)		

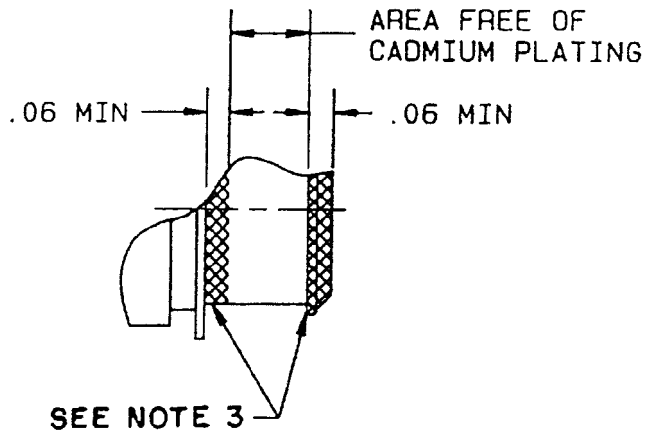

FIGURE 2 - SELECTIVE PLATING (SEE NOTE 3)

TABLE 1 – FIGURE 1 SHELL SIZE AND DIMENSIONS

ACCESSORY SHELL SIZE	SHELL SIZE CODE (REF)	A MAX DIA	B DIA ±.010 ENTRY SIZE		C DIA REF	
			02	03	02	03
9	A	.858 (21.8)	N/A	.250 (6.4)	N/A	.395 (10.0)
11	B	.984 (25.0)	N/A	.312 (7.9)	N/A	.457 (11.6)
13	C	1.157 (29.4)	.312 (7.9)	.438 (11.1)	.457 (11.6)	.583 (14.8)
15	D	1.279 (32.5)	.438 (11.1)	.562 (14.3)	.583 (14.8)	.707 (18.0)
17	E	1.406 (35.7)	.500 (12.7)	.625 (15.9)	.645 (16.4)	.770 (19.6)
19	F	1.516 (38.5)	.625 (15.9)	.750 (19.1)	.770 (19.6)	.895 (22.7)
21	G	1.642 (41.7)	.625 (15.9)	.812 (20.6)	.770 (19.6)	.957 (24.3)
23	H	1.768 (44.9)	.688 (17.5)	.938 (23.8)	.829 (21.1)	1.083 (27.5)
25	J	1.889 (48.0)	.750 (19.1)	1.000 (25.4)	.895 (22.7)	1.145 (29.1)

NOTES:

1. DIMENSIONS ARE IN INCHES.
2. METRIC EQUIVALENTS ARE GIVEN FOR GENERAL INFORMATION ONLY AND ARE BASED UPON 1.00 (25.4 MM).
3. CADMIUM/NICKEL INTERFACE SHALL BE COATED WITH POLYSULFIDE SEALANT.
4. PART SUPPLIED WITH STANDARD DETENTED SELF-LOCKING WHICH PROVIDES A POSITIVE AUDIBLE DETENTED COUPLING. OPTION 'N' IS A FREE SPINNING SELF-LOCKING COUPLING.
5. RIBBED, KNURL OR SURFACE ROUGHNESS 125-250 IN ACCORDANCE WITH ANSI B46.1

REQUIREMENTS:

DESIGN AND CONSTRUCTION:

1. DIMENSIONS AND CONFIGURATION: SEE FIGURE 1 AND TABLE 1.
2. INTERFACE DIMENSIONS: SHALL CONFORM TO SAE AS85049 FIGURE 3.
3. COUPLING NUT: SHALL BE CAPTIVATED TO THE ADAPTER BODY AND ROTATEABLE.
4. MATERIAL AND FINISH: IN ACCORDANCE WITH SAE AS85049 AND TABLE 2 HEREIN.

 An SAE International Group	<b>AEROSPACE STANDARD</b>	<b>SAE AS85049/88</b> SHEET 2 OF 4	<b>REV.</b> <b>B</b>
	(R) CONNECTOR ACCESSORIES, ELECTRICAL, BACKSHELL, STRAIGHT, SELF-LOCKING, SHIELD BAND TERMINATION (RFI/EMI), SHRINK BOOT ACCOMMODATION, CATEGORY 3B (FOR MIL-DTL-38999 SERIES III AND IV CONNECTORS)		

TABLE 2 - MATERIAL AND FINISH

Finish	Material
G – Electroless Nickel <u>1/</u> (Space grade) N – Electroless Nickel <u>1/</u> P – Cadmium Olive Drab over Electroless Nickel, (Selective Plating see figure 2) <u>2/</u> W – Cadmium Olive Drab <u>2/</u> X – Nickel Fluorocarbon Polymer Z – Zinc Nickel <u>2/</u> YP – Pure Dense Electrodeposited Aluminum, (Selective Plating – see figure 2) ZP – Zinc Nickel (Selective Plating, see figure 2) <u>2/</u>	Aluminum Alloy
J – Cadmium Olive Drab <u>2/</u> L – Cadmium Olive Drab over Electroless Nickel, (Selective Plating-see figure 2) <u>2/ 3/</u> M – Electroless Nickel XC – Nickel Fluorocarbon Polymer YL – Pure Dense Electrodeposited Aluminum, (Selective Plating see figure 2) <u>3/</u> ZC – Zinc Nickel <u>2/</u> ZL – Zinc Nickel (Selective Plating see figure 2) <u>2/ 3/</u>	Composite

1/ G AND N FINISH NOT FOR NAVY USE, RESTRICTED TO AIR FORCE SPACE APPLICATIONS ONLY.

2/ P, W, Z, ZP, J, L, ZC AND ZL FINISHES ARE NOT FOR USE IN SPACE APPLICATIONS. ALSO SEE SPECIFICATION NOTE.

3/ MUST MEET THE REQUIREMENTS AND PASS TESTS FOR FINISH J.

PART OR IDENTIFYING NUMBER (PIN):

EXAMPLE:

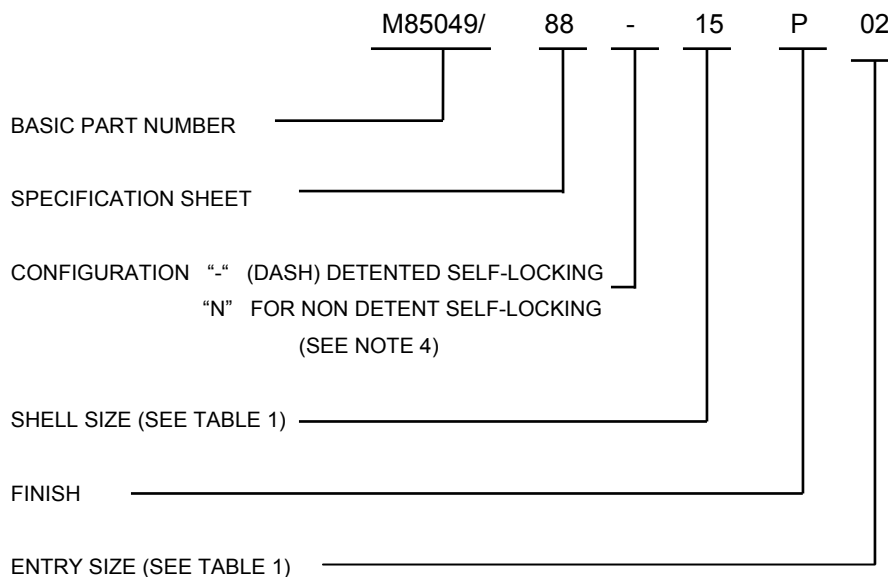

QUALIFICATION: SEE SAE AS85049, CATEGORY 3B.

SPECIFICATION NOTES:

NOTICE

THIS DOCUMENT REFERENCES A PART WHICH CONTAINS CADMIUM AS A PLATING MATERIAL. CONSULT LOCAL OFFICIALS IF YOU HAVE QUESTIONS CONCERNING CADMIUM'S USE.

A CHANGE BAR (I) LOCATED IN THE LEFT MARGIN IS FOR THE CONVENIENCE OF THE USER IN LOCATING AREAS WHERE TECHNICAL REVISIONS, NOT EDITORIAL CHANGES HAVE BEEN MADE TO THE PREVIOUS ISSUE OF THIS DOCUMENT. AN (R) SYMBOL TO THE LEFT OF THE DOCUMENT TITLE INDICATES A COMPLETE REVISION OF THE DOCUMENT, INCLUDING TECHNICAL REVISIONS. CHANGE BARS AND (R) ARE NOT USED IN ORIGINAL PUBLICATIONS NOR IN DOCUMENTS THAT CONTAIN EDITORIAL CHANGES ONLY.

 <i>An SAE International Group</i>	<b>AEROSPACE STANDARD</b>	<b>SAE AS85049/88</b> SHEET 4 OF 4	<b>REV.</b> <b>B</b>
	(R) CONNECTOR ACCESSORIES, ELECTRICAL, BACKSHELL, STRAIGHT, SELF-LOCKING, SHIELD BAND TERMINATION (RFI/EMI), SHRINK BOOT ACCOMMODATION, CATEGORY 3B (FOR MIL-DTL-38999 SERIES III AND IV CONNECTORS)		